

FLO₂ Twin Fan Units

Installation, Operation and Maintenance Manual

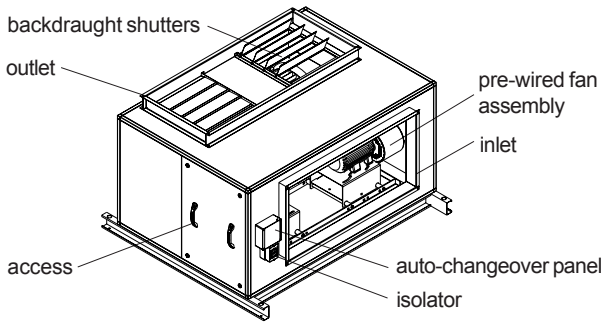

Fig.1 Typical unit layout

IMPORTANT This manual must be read in full before Installation, Operation and Maintenance of the unit/s supplied

	Contents	page
1	Introduction	1
2	Installation	1
3	Set-up	1
4	Wiring	3
5	Maintenance	7
6	Warranty	8
7	Declaration of Conformity	9

1 Introduction

The FLO₂ series is a range of twin fan units, direct and belt driven, with duties up to 4m³/s. Suitable for plant-room, ceiling void and external locations, as standard each unit is provided pre-wired to an auto-changeover panel and isolator assembly. The standard ambient operating temperature of the unit is -10 to +35°C.

For further technical details contact VES on **08702 404340**, quoting the sales order (SO) number and the unit type as found on the unit nameplate or visit **www.ves.co.uk**.

2 Installation

The entire system must be considered for safety purposes and it is the responsibility of the installer to ensure that all of the equipment is installed in compliance with the manufacturer's recommendations, with due regard to the current HEALTH AND SAFETY AT WORK ACT and conforms to all relevant statutory regulations. Where a unit is installed so that a failure of components could result in injury to personnel, precautions should be taken to prevent such an injury.

Immediately upon receipt of goods, check for possible damage in transit, paying particular attention to fan impellers, motor and flexible connections. Prior to installation please check to ensure smooth rotation of the impellor after transit. Also check to ensure that any ancillary items are included. These will normally be supplied fitted or taped to the unit (in the case of small items).

In the event of any damage having occurred or if any item found to be missing, it is essential to inform VES Andover Ltd. within **3 working days** of delivery quoting sales order (SO) number and the unit type as found on the unit nameplate. After this period we will be unable to accept any claim for damaged or missing goods.

IMPORTANT This unit should NOT be lifted by handles, lids or housings

When moving the unit, handle with care and in such a manner as to avoid damaging the external finish as this may reduce the ability to resist corrosion. Units are to be rigged and lifted using spreaders, taking into account the weight of the unit, lifting gear should be arranged so as not to bear on the casework.

It is the installer's responsibility to ensure that access panels are not obstructed in any way and safe working access for maintenance is provided in line with Health and Safety and Building Regulations

For optimum unit performance, careful consideration must be paid to the location of the unit in relation to the ductwork and associated items; placing the unit directly adjacent to a bend in ductwork will impede airflow and reduce performance.

Consideration must also be given by the installer for adequate illumination of the unit's location in order for safe maintenance.

Where provided, flanges and spigots should not be used to support the ductwork and used solely as a means of ductwork connection. Further consideration should be given to the unit's position and secured into place as appropriate. This is especially important with external mounting as the wind and elements may effect the overall stability of the unit.

3 Set-up

Motor and electrical details must be checked prior to connection to electricity supply. All motor information can be found on the unit data sheet supplied attached to the unit. Sizes 1,2 and 3 operate with direct drive fans; ensure that the impeller blades are not damaged and spin freely. For units 236 & 337 featuring constant pressure fans see later in this document for set up details. Sizes 4 & 5 are belt driven units; ensure that the transit bolts and spacer are removed from fan and motor frame. These were to protect the anti-vibration mounts and flexible connections during delivery and must be removed for these items to be effective.

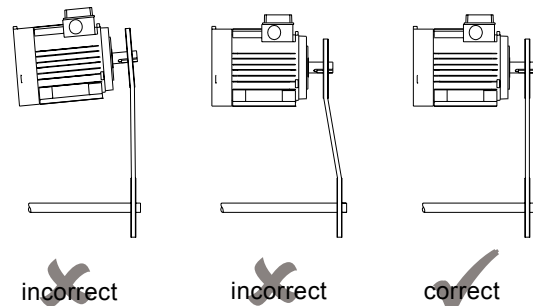

Fig.2 Pully alignment

Ensure correct pulley alignment as indicated in *fig.2* above. To check the tension of the drive belt apply a force perpendicular to the centre of the belt span sufficient to deflect the belt 16mm for every metre of span length, as indicated in *fig.3*. The force required to deflect the belt should be from 0.5 to 0.8kg. After the unit has been positioned, re-check that the impeller is smooth running as this may have moved during transit.



FLO₂ Twin Fan Units

Installation, Operation and Maintenance Manual

Fig.3 Belt tension

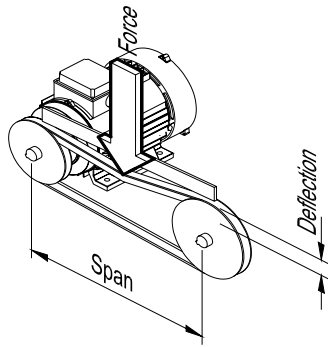

3 Set-up continued

Constant pressure fans only: The VES constant pressure fans feature a programmable electronic motor for various applications, typically used for sensor-less control for constant pressure environments. The fan characteristics include variable frequency regulation giving high efficiency at low speed with a working range of between 100-2000 rpm. The fan has a high efficiency motor controlled with a 16 KHz inverter to help eliminate acoustic noise. The fan is supplied with a 230V 50Hz supply, with a working temperature with air over the motor of 0° to 50°C.

IMPORTANT !

Before attempting to carry out any work on our units, the unit **MUST BE COMPLETELY ISOLATED** from its electrical supply. For constant pressure units ensure a minimum of 5 minutes after electrical disconnection of before removing access panels. This will allow any moving parts to come to a rest and for the capacitors to discharge fully before starting work.

Each fan has been pre-programmed to maintain the specified pressure in a ducted system, an inverter controlling the fan speed as required. This programming includes up to 8 possible constant pressure variations for each fan see fig.5. Once the desired system pressure has been established the fan pressure selection setting can be adjusted via a Dip switch arrangement found under the terminal cover on the fan motor assembly see fig.4. (The fans are factory default set to 200Pa, dip switch selection No. 4). After the initial switch set-up to each fan, no further programming or adjustment should be necessary taking care to ensure that both fans have been set-up the same.

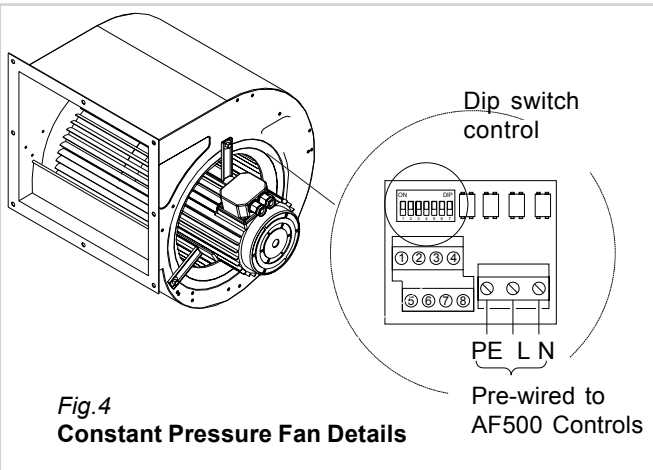
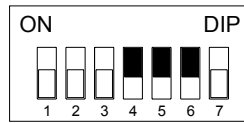

Fig.5

Constant Pressure Selection Setting



Switch Selection No.1

FLO236: 140Pa FLO337: 50Pa
 Switch 4 = ON
 Switch 5 = ON
 Switch 6 = ON

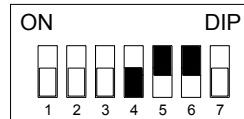

Switch Selection No.2

FLO236: 160Pa FLO337: 100Pa
 Switch 4 = OFF
 Switch 5 = ON
 Switch 6 = ON

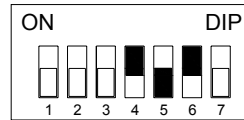

Switch Selection No.3

FLO236: 180Pa FLO337: 150Pa
 Switch 4 = ON
 Switch 5 = OFF
 Switch 6 = ON

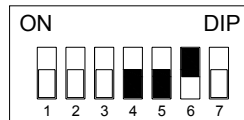

Switch Selection No.4

FLO236: 200Pa FLO337: 200Pa
 Switch 4 = OFF
 Switch 5 = OFF
 Switch 6 = ON

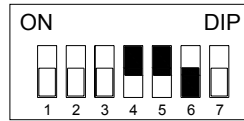

Switch Selection No.5

FLO236: 220Pa FLO337: 250Pa
 Switch 4 = ON
 Switch 5 = ON
 Switch 6 = OFF

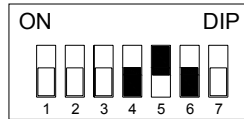

Switch Selection No.6

FLO236: 240Pa FLO337: 300Pa
 Switch 4 = OFF
 Switch 5 = ON
 Switch 6 = OFF

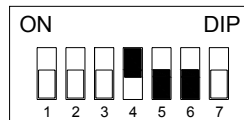

Switch Selection No.7

FLO236: 260Pa FLO337: 350Pa
 Switch 4 = ON
 Switch 5 = OFF
 Switch 6 = OFF

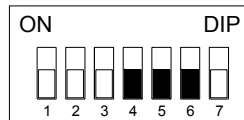

Switch Selection No.8

FLO236: 280Pa FLO337: 400Pa
 Switch 4 = OFF
 Switch 5 = OFF
 Switch 6 = OFF

The default setting for these fans is 200Pa with dipswitch settings 6 ON, 4 & 5 OFF. For alternative constant pressure settings select the appropriate dipswitch arrangement as above

Dipswitch settings for switches 1,2,3 & 7 are factory set under normal working conditions these should NOT be altered. For reference only these settings should be: 1, 2, 3 & 7 OFF



FLO₂ Twin Fan Units

Installation, Operation and Maintenance Manual

4 Wiring

VES twin fan units contain two centrifugal fans with either acting as a standby fan to ensure continuous airflow in the event of a fan or motor failure.

Each fan has a set of back draught shutters, which prevent recirculation of air through the standby fan. These shutters operate micro-switches which control the standby fan if the duty fan ceases to move air. The micro-switches and fan motors are pre-wired to the AF500 auto-changeover panel located on the outside of the twin fan unit case.

All electrical connections to any unit must be carried out in accordance with the current edition of the

I.E.E REGULATIONS and only competent Electricians should be allowed to affect any electrical work to our units.

IMPORTANT

Do not connect any unit to an electrical supply voltage outside of that indicated on the motor nameplate.

Mains cables should be suitably sized see *fig.6* and terminated as shown on the appropriate wiring diagram see *fig.7, 8 & 9*. All standard units are supplied pre-wired to a local isolator.

**Fig.6
Electrical Details**

Model FLO ₂	VES Fan Ref.	Motor Input (W)	FLC* (A)	Fan Speed (rpm)	Supply Voltage
111	AL121	120	0.55	1590	230V 1Ph 50Hz
112	AL221	245	1.10	1365	230V 1Ph 50Hz
113	AL321	350	1.45	1945	230V 1Ph 50Hz
214	AL441	460	2.10	1280	230V 1Ph 50Hz
215	AL541	675	3.15	1380	230V 1Ph 50Hz
223	GZ361	320	1.60	860	230V 1Ph 50Hz
224	GZ461	525	2.47	860	230V 1Ph 50Hz
226	GZ641	1310	5.70	1380	230V 1Ph 50Hz
236	GZ641/I	1250	5.20	N/A	230V 1Ph 50Hz
325	GZ561	661	3.10	860	230V 1Ph 50Hz
326	GZ641	1150	5.10	1380	230V 1Ph 50Hz
327	GZ741	1650	6.80	1380	230V 1Ph 50Hz
337	GZ741/I	1300	7.80	N/A	230V 1Ph 50Hz
428-1	GZ861	1850	8.40	900	230V 1Ph 50Hz
428-3	GZ863	1100	2.85	860	400V 3Ph 50Hz
429-1	GZ961	2740	12.10	850	230V 1Ph 50Hz
429-3	GZ963	2850	7.00	850	400V 3Ph 50Hz

Model FLO ₂	Motor Size (kW)	FLC* (A)	SC** (A)	Fan Speed (rpm)	Supply Voltage
441/080-15-1	1.5	9.0	42.3	800	230V 1Ph 50Hz
441/090-15-1	1.5	9.0	42.3	900	230V 1Ph 50Hz
441/100-22-1	2.2	12.5	57.5	1000	230V 1Ph 50Hz
441/110-22-1	2.2	12.5	57.5	1100	230V 1Ph 50Hz
441/080-15-3	1.5	3.6	20.52	800	400V 3Ph 50Hz
441/090-15-3	1.5	3.6	20.52	900	400V 3Ph 50Hz
441/100-22-3	2.2	5.3	25.44	1000	400V 3Ph 50Hz
441/110-22-3	2.2	5.3	25.44	1100	400V 3Ph 50Hz
441/120-30-3	3.0	6.8	31.28	1200	400V 3Ph 50Hz
441/130-30-3	3.0	6.8	31.28	1300	400V 3Ph 50Hz
541/075-40-3	4.0	9.2	55.20	750	400V 3Ph 50Hz
541/085-40-3	4.0	9.2	55.20	850	400V 3Ph 50Hz
541/095-40-3	4.0	9.2	55.20	950	400V 3Ph 50Hz
541/095-55-3	5.5	11.4	74.10	950	400V 3Ph 50Hz
541/105-40-3	4.0	9.2	55.20	1050	400V 3Ph 50Hz
541/105-55-3	5.5	11.4	74.10	1050	400V 3Ph 50Hz
541/115-55-3	5.5	11.4	74.10	1150	400V 3Ph 50Hz
541/115-75-3	7.5	14.8	96.20	1150	400V 3Ph 50Hz
541/125-55-3	5.5	11.4	74.10	1250	400V 3Ph 50Hz
541/125-75-3	7.5	14.8	96.20	1250	400V 3Ph 50Hz
541/135-75-3	7.5	14.8	96.20	1350	400V 3Ph 50Hz

FLC* Full Load Current SC** Nominal Starting Current



FLO₂ Twin Fan Units

Installation, Operation and Maintenance Manual

Fig.7

**Standard wiring arrangement
 230v 1Ph 50Hz**

For FLO₂ Units:
 111, 112, 113
 214, 215, 223, 224, 226, 236
 325, 326, 327, 337

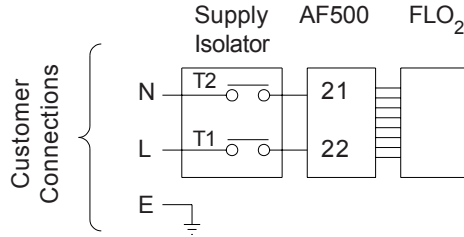

Fig.8

**Standard wiring arrangement
 230v 1Ph 50Hz**

For FLO₂ Units:
 428-1
 429-1
 441 (1PH)

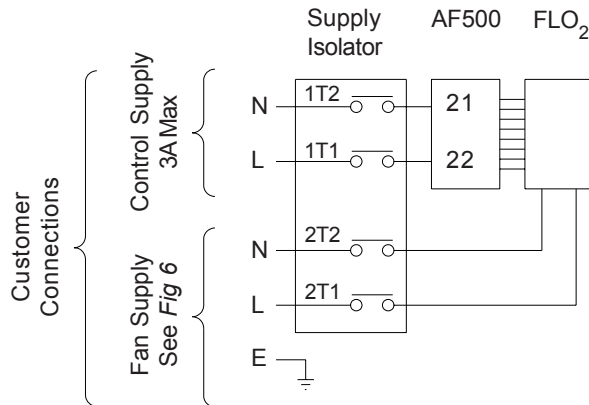
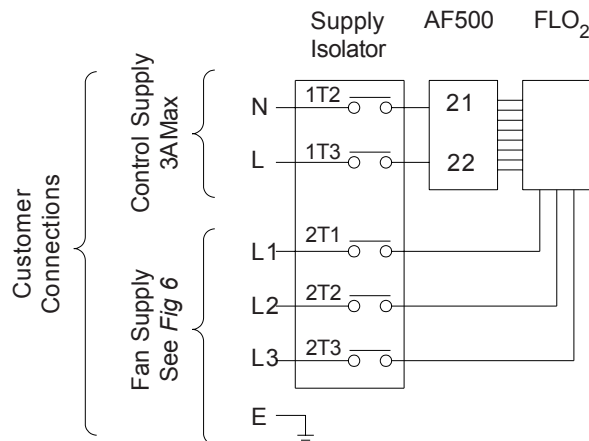

Fig.9

**Standard wiring arrangement
 400v 3Ph 50Hz**

For FLO₂ Units:
 428-3
 429-3
 441(3PH)
 541(3PH)





FLO₂ Twin Fan Units

Installation, Operation and maintenance Manual

Fig. 10
AF 500 Wiring diagram

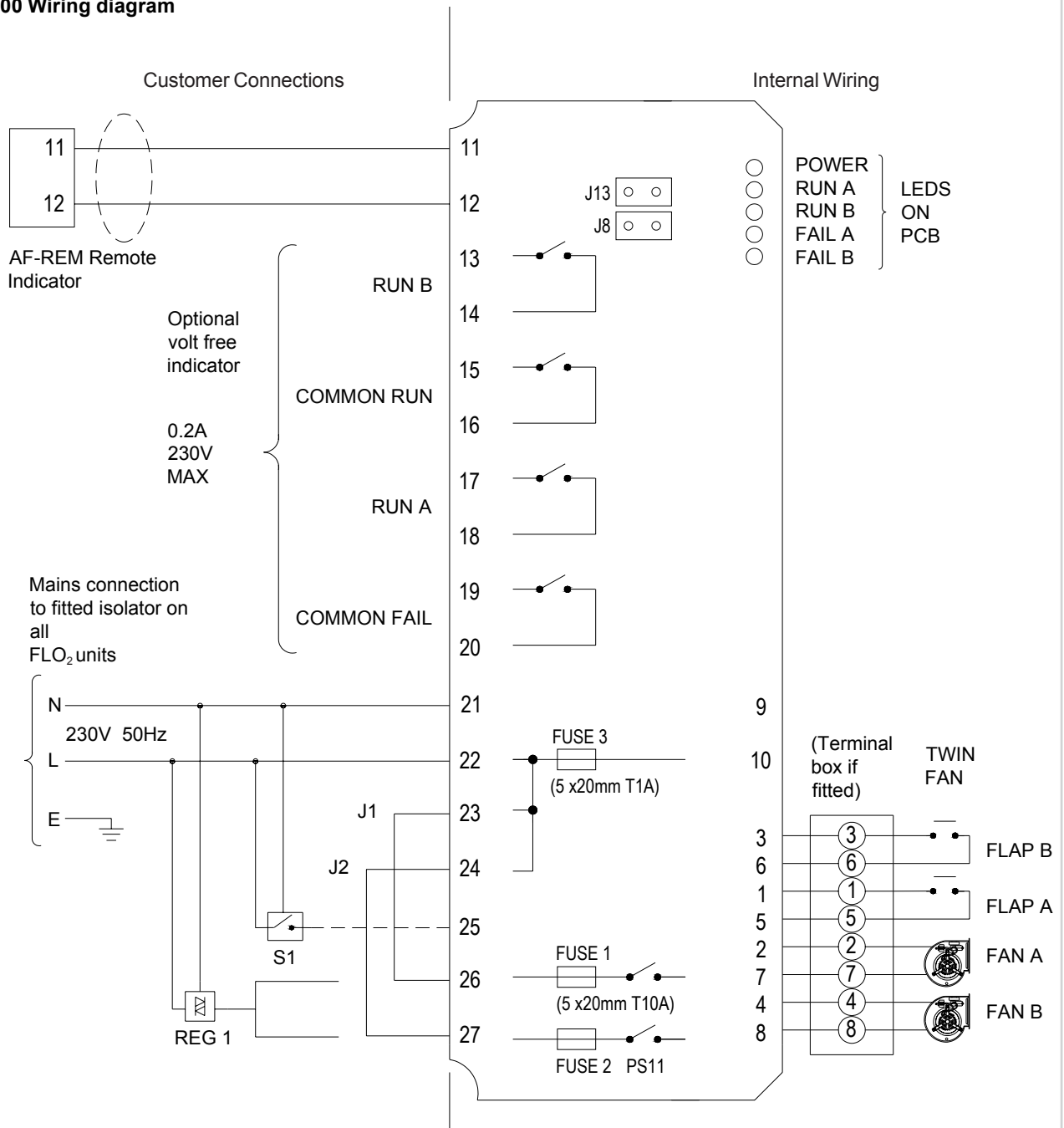

Details

- Supply: 230V 50Hz
- Ambient: -10 to +35°C
- Protection: IP54
- Fan use: 5 x 20mm T10A
- Volt free indicator: 230V 0.24A maximum
- Duty share time: 12 hours run time memory
- Fan test: Both fans are run in sequence at power up, commencing with non-duty fan

10sec fan test - 10sec flap test - 10sec fan test - Run

Fan fail: To reset, remove power from AF500

For additional features contact VES



FLO₂ Twin Fan Units

Installation, Operation and Maintenance Manual

Fig.11

Twin fan unit remote status indicator

Remote single multi coloured LED indicator informs the operator of the current status of the FLO₂ unit. Fits standard single gang switch box. 2-core screened cable connection, maximum length 50 metres. Below is a list of the LED states and what they indicate.

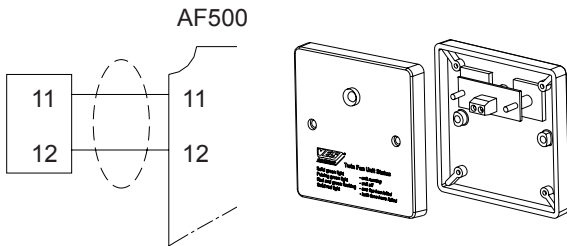

- | | |
|---------------------|--------------------------------|
| Solid green | - Unit running |
| Pulsing green | - Unit standby |
| Alternate green/red | - One fan failed - One fan run |
| Solid red | - Both fans failed |

Fig.12

Remote on/off (230V)

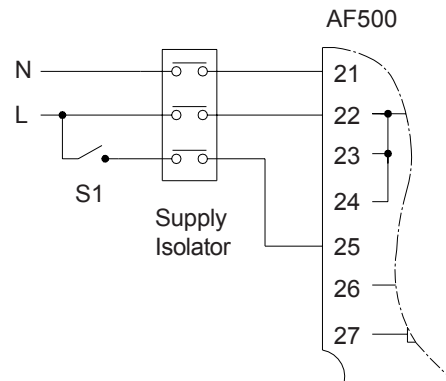

S1 = Switch timeclock/PIR etc. remove link J8

Fig.13

Remote wiring options: Speed control, 1 phase FLO₂ sizes 1 to 3

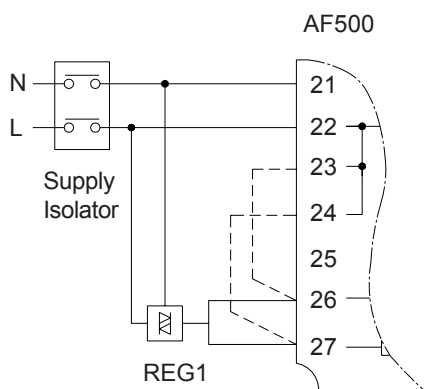

REG 1 refer to VES for speed control
 Remove links 23/26 and 24/27

Fig.14

Volt free status indicator

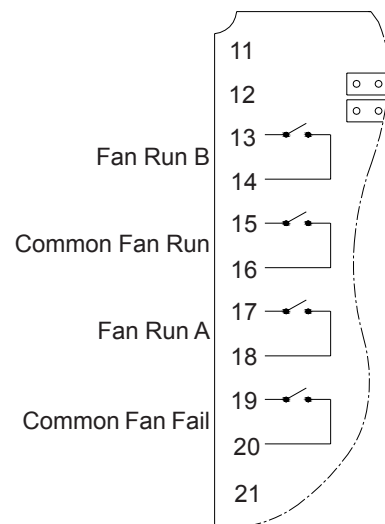

Contacts 230V 0.2A



FLO₂ Twin Fan Units

Installation, Operation and Maintenance Manual

5 Maintenance

IMPORTANT

Before attempting to carry out any maintenance work, investigative or repair work on our units, the unit **MUST BE COMPLETELY ISOLATED** from its electrical supply. Ensure a minimum of two minutes after electrical disconnection before removing access panels. This will allow any moving parts to come to a rest

In general, this series of units require very little maintenance. All fan and motor bearings are supplied fully greased and lubricated and are sealed for life. In the unlikely event of component failure, spares are available from stock at VES Andover Ltd.

IMPORTANT

Before attempting to carry out any work on our units, all accompanying documentation including warning labels on the unit must be referenced.

WARNING

When used in conjunction with an Inverter for speed control, a minimum of 5 minutes should be given to allow for the capacitors to discharge before starting work

Recommended checks

Drive Belts - The 'v' belts should be inspected from time to time and any slackness taken up by moving the position of the motor plate, slacken bolts and slide the motor plate down, retighten the bolts. Under average conditions the majority of stretch takes place in 'v' belts during the first few days under load and this should be taken into consideration when commissioning the unit.

Excessive wear on both sides of the 'v' belts usually indicates a misalignment of the pulleys and this should be rectified at once see *fig.2*. New and used 'v' belts should not be run together in the same set and 'v' belts of different types and brands should not be mixed. Always fit ALL NEW matched belts in the same set.

This range of units will require regular maintenance if located in greasy air systems. In order to keep the unit in good order the following maintenance routine is recommended:

Three Monthly Check

Check for contaminants in the system, especially around the impeller. Remove the any residue if necessary. Failure to keep the unit free of such contaminants could result in a reduction of performance or fans to become out of balance, leading to bearing failure.

Six Monthly Check

The belt drive should be thoroughly checked. Belts are subject to fatigue and will stretch over a period of time. Again, within normal operating conditions, belts tend to stretch in the first few days of running. Inspection of belts at this early stage is advised. After this initial period, regular 6 monthly checks should be made. If belts are found to be loose or worn, retighten or replace as necessary. Refer to *fig.3* for the recommended tension.

IMPORTANT

It is critical that after any maintenance work has been conducted that all components removed/replaced be refitted correctly by a competent engineer.

Fault finding

Please note the FLO₂ units and controllers are factory run tested prior to dispatch.

If the LED on the remote twin fan status indicator is flashing red and green check:

- Flaps not opening (possibly due to excessive resistance in the system)
- Check fan connections
- Fan fuse has blown
- Motor failure
- Very dirty fan
- Micro-switch not operating
- Correct speed controller is fitted
- Correct fan rotation
- If used, check the overloads are correctly set

If the LED on the remote is solid red, both fans have failed, check:

- Fan fuses
- Electrical connections
- PCB failure in AF 500
- Condensation

WEEE Directive



At the end of their useful life the packaging and product should be disposed of via a suitable recycling centre.
Do not dispose of with normal household waste.
Do not burn

When enquiring after or ordering spares contact VES Spares Department, quoting the sales order (SO) number and unit type as found on the unit nameplate.

Telephone	08702 40 43 40
Fax	08702 40 45 50



PLEASE ENSURE THAT THIS DOCUMENT IS PASSED ON TO THE END USER.

We reserve the right to alter the specification without notice

©VES Andover Ltd. 2006
No part of this publication may be photocopied or otherwise reproduced without the prior permission in writing of VES Andover Ltd.



FLO₂ Twin Fan Units

Installation, Operation and Maintenance Manual

6 Warranty

Extended Warranties

All VES Andover Products come with a one year guarantee from date of dispatch, which covers parts and labour. You can now extend this with the following options:

Option 1. FREE extended Warranty

We can offer you a maintenance agreement that keeps this equipment in tip-top condition. If you take out this agreement, we will extend the warranty **free of charge for up to 5 years**, providing the regular maintenance agreement remains in place.

Option 2. 12-24 Month Extended Warranty

12-24 months from the date of dispatch. This can be covered at a cost of just 3% of order value. (minimum charge £50.00).

Option 3. 12-36 Month Extended Warranty

12-36 months from date of dispatch. For this cover, the charge is 6% of order value (Minimum charge £80)

Please State which option you require when you place your order. A transferable certificate will then be issued to you. *Please note, this offer excludes condensing units. We would be happy to quote you for these separately.*

Register for separate spares reminders and get a 10% discount

Register for this free service and we will automatically send you a regular reminder detailing the consumable spares for this unit, together with their current list prices.

You will then be entitled to a 10% discount off any spares.

To arrange any of these options.

or **Phone: 023 8046 1150**
Email: spares@ves.co.uk

Stating the sales order and reference number from the unit.



FLO₂ Twin Fan Units

Installation, Operation and Maintenance Manual



Declaration of Conformity

Date: 20th June 2005
Product: FLO₂ Twin Fan Units
Type: FLO
Manufacturer: VES Andover Limited

The product above is produced in accordance with EC Council Directives:

98/37/EC (Machinery Directive)
89/336/EEC and amendment 92/31/EEC (Electromagnetic Compatibility Directive)
73/223/EEC and amendment 93/68/EEC (Low Voltage Directive)

The European Harmonised Standards applied are:

BS EN ISO 12100, EN 294, EN61000, EN 60204-1

The National Standards applied in particular are :

BS 848 Part 1

Basis of Self attestation:

Quality Assurance to ISO 9001-2000, BSI Reg. Firm Cert. No. Q5375

Signature of Manufacturer:

Position of Signatory:

Technical Director