

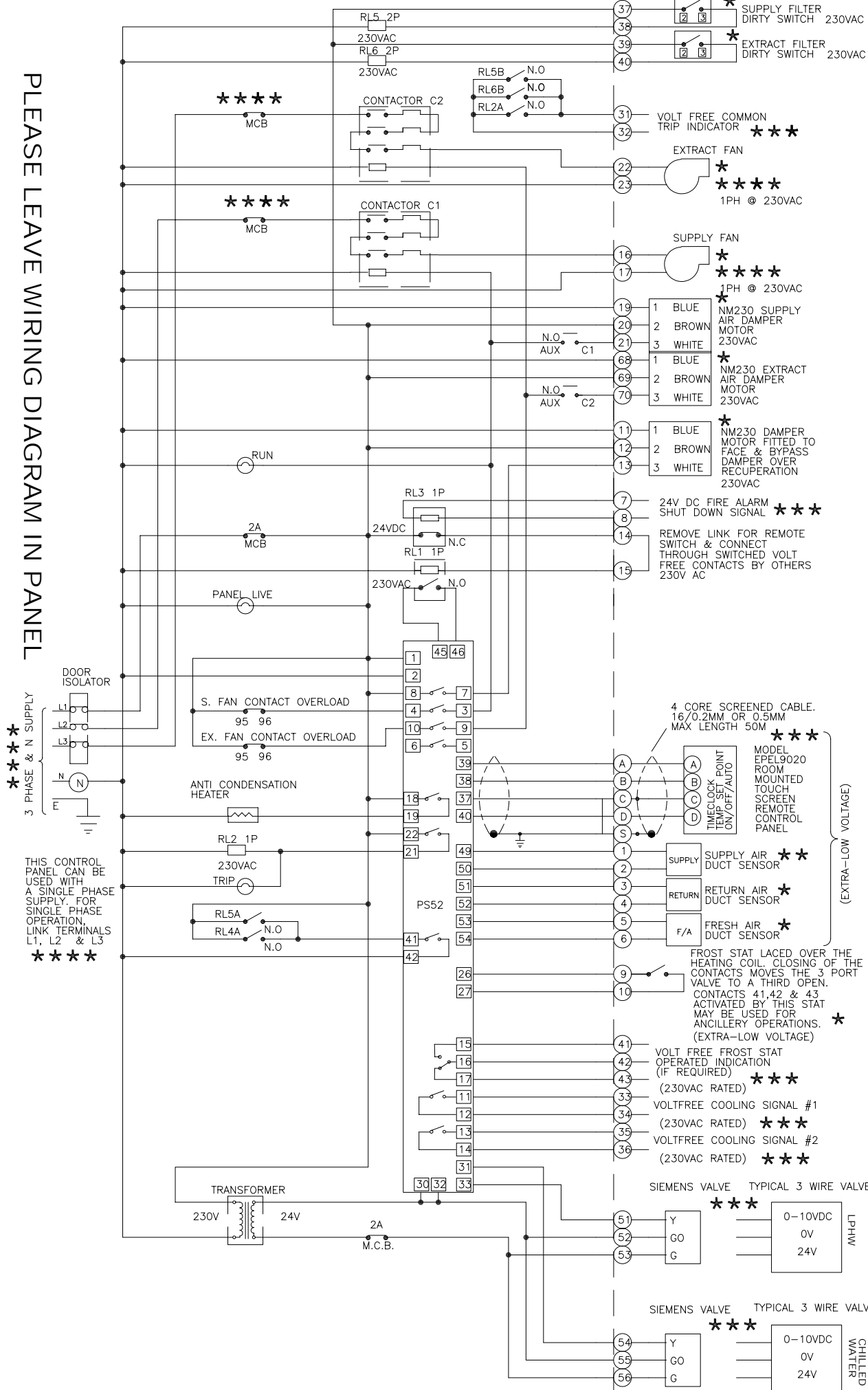

INTERNAL WIRING | FIELD CONNECTIONS

PLEASE LEAVE WIRING DIAGRAM IN PANEL



| | | | |
|---|-----------------------------|-------------------------|--------|
| TITLE: CPCX-1/642/W/C/D (1 OF 2) | | ISSUE: A | |
| CHECKED: KF | DATE: 31.10.08 | DRAWING NO. 95004469 | |
| DRAWN: NZ | DATE: 08.09.08 | ID.445 ISSUE: E | |
| C.NOTE No. CPN00659 | DATE & INITIAL: NZ 19.03.09 | DESCRIPTION: MCB CHANGE | REV: A |
| 2007 PRODUCT PROTECTED BY DESIGN RIGHT | | | |
| VES ANDOVER LTD. EAGLE CLOSE, CHANDLERS FORD INDUSTRIAL ESTATE, CHANDLERS FORD, EASTLEIGH, HAMPSHIRE, ENGLAND, SO63 4NF TEL: (08448) 15 60 60 FAX: (023) 80275696 E.MAIL: vesli@ves.co.uk WEB SITE: www.ves.co.uk | | | |
|  | | | |

