

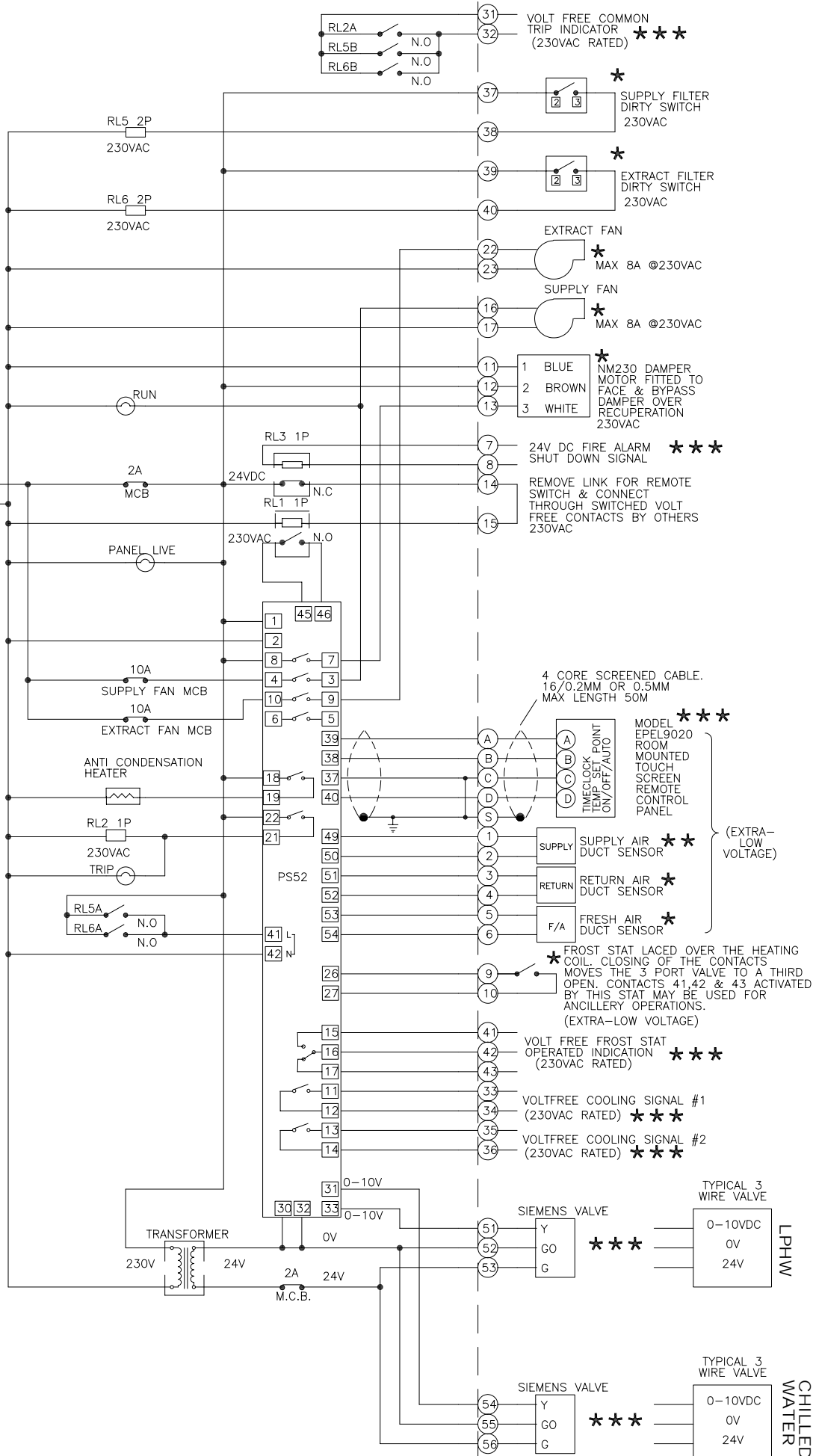

INTERNAL WIRING

FIELD CONNECTIONS

MAX FLC: 18A @ 230V 50HZ
1 PHASE SUPPLY

PLEASE LEAVE WIRING DIAGRAM IN PANEL



TITLE: CPCO-1/632/W/C/D (1 OF 2)		DRAWING No. 95004474		ISSUE A
CHECKED: KF	DATE: 31.10.08	NOTES:		
DRAWN: NZ	DATE: 24.10.08			
C.NOTE No. CPN00650	DATE & INITIAL NZ 18.03.09	DESCRIPTION: SINGLE PHASE CHANGE (PS17)	REV: A	2007 PRODUCT PROTECTED BY DESIGN RIGHT
VES ANDOVER LTD. EAGLE CLOSE, CHANDLERS FORD INDUSTRIAL ESTATE, HAMPSHIRE, ENGLAND, SO63 4NF TEL: (08448) 15 60 60 FAX: (023) 80275696 E.MAIL: vesli@ves.co.uk WEB SITE: www.ves.co.uk				

ID.445 ISSUE: E

INFORMATION AND KEY



INDICATES PRE-WIRED ITEMS IF FITTED CONTROL PANEL OPTION IS PRE ORDERED.

IF PRE-WIRED OPTION IS ORDERED, SOME FINAL CONNECTIONS WILL NEED TO BE MADE BY CUSTOMER FOR MULTISECTION UNITS.

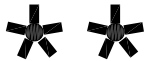

TO BE FITTED IN SUPPLY DUCTWORK; A MINIMUM OF 4M DOWN STREAM OF AHU.



INDICATES CUSTOMER CONNECTIONS IF PRE-WIRED OPTION IS ORDERED.

- NOTE:
1. SET TO HEATING & COOLING ON REMOTE. COMMISSIONING INSTRUCTIONS FOR REMOTE CONTROL PANEL ARE IN PS51 O&M ID756.
 2. SUPPLY SENSOR MUST BE CONNECTED, BUT ALL OTHER COMPONENTS MAYBE USED AS REQUIRED.
 3. FILTER(S) DIRTY WILL CAUSE SERVICE FAULT TO BE DISPLAYED ON REMOTE.
 4. FAN FAILURE WILL CAUSE GENERAL FAULT TO BE DISPLAYED ON REMOTE.
 5. EARTHS NOT SHOWN FOR CLARITY.
 6. 23 TERMINAL NUMBER(S) MARKED ON PRESSURE SWITCH BODY.

2007 PRODUCT PROTECTED BY DESIGN RIGHT		VES ANDOVER LTD. EAGLE CLOSE, CHANDLERS FORD INDUSTRIAL ESTATE, CHANDLERS FORD, EASTLEIGH, HAMPSHIRE, ENGLAND, SO63 4NF TEL: (08448) 15 60 60 FAX: (023) 80275696 E.MAIL: veslig@ves.co.uk WEB SITE: www.ves.co.uk		REV	A	DESCRIPTION	SINGLE PHASE CHANGE (PS17)	DATE & INITIAL	NZ 18.03.09	C.NOTE No.	CPN00650	DRAWN:	NZ	CHECKED:	KF 31.10.08	TITLE:	CPC0-1/632/W/C/D (2 OF 2)	DRAWING No.	95004474	ISSUE	A
																ID.445 ISSUE: E					

