



EURO100/150

In-line Extract Fans

! IMPORTANT

This manual must be read in full before Installation, Operation and Maintenance of the units supplied. Please ensure that this document is passed to the end user. This manual forms an integral part of the product and should be kept for the working life of the product. Additional copies of this and supporting documents are available by contacting VES or by visiting www.ves.co.uk and following the 'Download O & M's' link.

The following symbols used within this document refer to potential dangers or advice for safe operation

-  Indicates hazards associated with electric current and high voltages
-  Indicates hazards that require safety advice for personnel and/or potential unit/property damage
-  Indicates important information

Unit Description

The EURO duct mounted inline fan for extract applications; for full unit details please see the unit specification later in the document.

Immediately upon receipt of your EURO fan, check there is no damage to the fan, and that the four fixing screws and matching wall plugs are included within the ancillary bag.

In the event of any damage having occurred or if any item is found to be missing, it is essential to inform VES Andover Ltd. within 7 days of delivery quoting sales order number and the unit type. After this period, VES would be unable to accept any claim for damaged or missing goods.

Part Number	Description	
EURO100.....	Inline duct mounted fan	Ø100
EURO150.....	"	Ø150

! IMPORTANT

Before attempting to carry out any work on our units, all accompanying documentation including warning labels on the unit must be referenced. Should it be necessary to remove any component ensure that these are secured into position once reinstalled. It is critical that after any maintenance work has been conducted that all components removed /replaced be refitted correctly by a competent engineer.

! IMPORTANT

EURO fans should be installed in accordance with current IEE Regulations BS7671 and the appropriate Building Regulations.

! IMPORTANT

For fan positioning refer to Building Regulation for specific requirements. If installed in a room containing a fuel burning device without a balanced flue, it is the installers responsibility to ensure that is enough replacement air to prevent any fumes being drawn back down the flue when the fan is operating at full speed. Euro fans are only suitable for mounting on the horizontal plane (flat), not vertically. The fan should be installed with an appropriate duct kit and consideration must be given to ensure that access to all moving parts of the fan are restricted when the fan is in use.

Dimensions (mm)	Ø	A	B	C
EURO100	98	98	98	55
EURO150	148	92.5	111	55

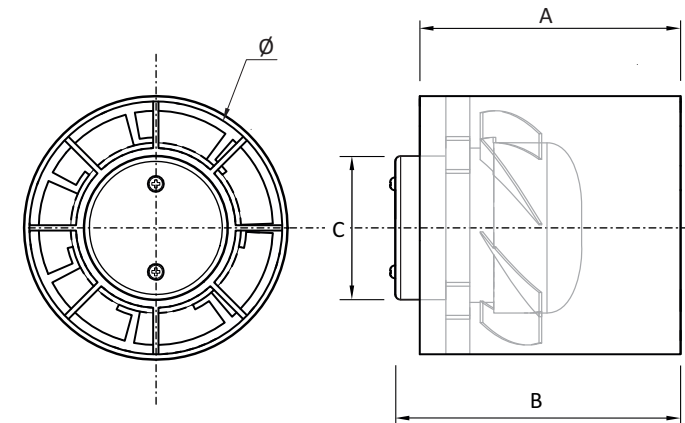

Specification

Power Supply	230VAC 50Hz
Operating Temperature	0~40°C
Speed (rpm)	2650
Power (W) (EURO100/150)	15/20
Current (A)(EURO100/150)	0.12/0.13
Insulation Class	Double insulated <input type="checkbox"/>
Motor Protection	IPX2
Motor Type	Sleeved



IMPORTANT

Before attempting to carry out any maintenance or repair work on our units, the unit **MUST BE COMPLETELY ISOLATED** from its electrical supply. Ensure a minimum of two minutes after electrical disconnection before attempting access. This will allow any moving parts to come to a rest.

Maintenance

These fans require little in the way of maintenance.

1. Before attempting to clean, ensure that the fan is isolated completely from the mains supply.
2. Loosen the collar and carefully clean the fan with a damp, lint free cloth. Thoroughly dry and refit.
3. **Do not** immerse the fan in water or other liquids to clean any other parts of the fan. Never use strong solvents to clean the fan. If the impellor is damaged or soiled replace the fan unit.

No other maintenance is required. For replacement fans or install kits please visit www.vesdirect.co.uk

Warranty

The fan is guaranteed against defects for 1 year from the date of purchase. If you have any problems, contact VES at the address shown below.



WEEE Directive

At the end of their useful life the packaging and product should be disposed of via a suitable recycling centre. Do not dispose of with normal household waste. Do not burn.

Standards

EURO fans conform to all relevant British and European standards and directives. Further information is available from VES Andover Ltd on request



Please ensure that this document is passed on to the end user
We reserve the right to alter the specification without notice ©VES Andover Ltd. 2010. No part of this publication may be photocopied or otherwise reproduced without the prior permission in writing of VES Andover Ltd.



Installation continued

- 1 Place the fan into position taking note of the direction of airflow arrow.

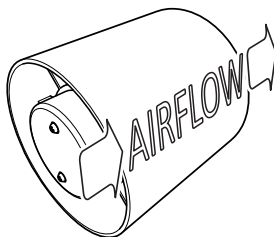

- 2 Using the EURO mounting bracket, determine a mounting position

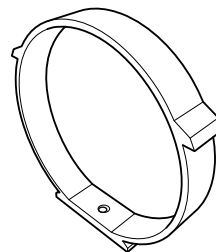

- 3 Unclip/open the mounting bracket and secure into position using the fixings provided. Plug mounting holes as required

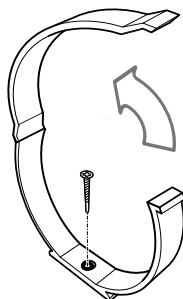

- 4 Replace the fan body and refasten the mounting bracket, holding the fan now into place

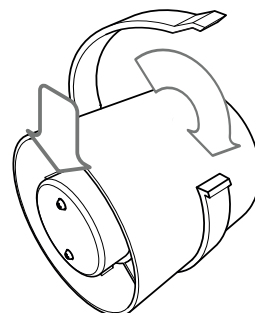

- 5 Wire the fan as per wiring diagram & instructions

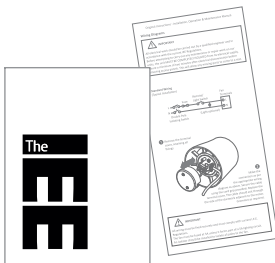

- 6 Secure flexible ducting to both spigots using jubilee clips or strangle band

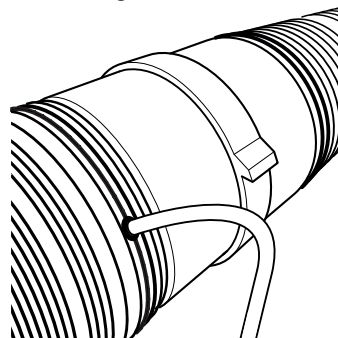

Wiring Diagrams



IMPORTANT

All electrical work should be carried out by a qualified engineer and in accordance with the current IEE Regulations. Before attempting to carry out any maintenance or repair work on our units, the unit **MUST BE COMPLETELY ISOLATED** from its electrical supply. Ensure a minimum of two minutes after electrical disconnection before attempting access. This will allow any moving parts to come to a rest.

Standard Wiring

(Typical Installation)

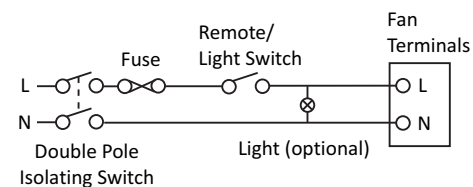

- 1 Remove the terminal cover, retaining all fixings

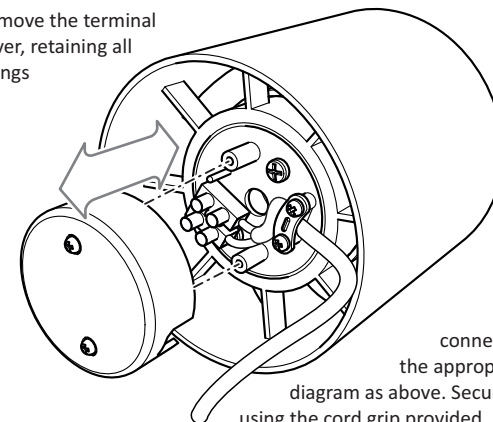

- 2 Make the connection as per the appropriate wiring diagram as above. Secure the cable using the cord grip provided. Replace the terminal cover. The cable should exit through the side of the ductwork adjacent to the motor. Grommet as required.



IMPORTANT

The fan must be fused at 3A unless it forms part of a 5A lighting circuit. An isolator should be installed to isolate all poles to the fan.