

# FLO<sub>2</sub>

## Twin fan units

*Huge duty range 0.025 to 4.0m<sup>3</sup>/sec*

*Plantroom, ceiling void or weatherproof location*

*Prewired controls*

*Low voltage remote status indicator*

*Many units available from stock*



*Go with a FLO*





The FLO<sub>2</sub> is an extraordinarily wide range of twin fan units for plantroom, ceiling void and external locations.

This leaflet provides all the information you need to select and specify in a straightforward manner.











## Main Features:

- All fans and motors fully vibration isolated within case. Additional anti-vibration mounts and flexible connections not required.
- The auto-changeover panel is fitted to the unit and pre-wired to the fans and micro switches. The twin fan unit status indicator panel can be remote mounted using low voltage twin core cable, and fitted onto a single gang electrical box, or surface mounted.
- All standard units will have a fitted local isolator.
- The weatherproof units have a single louvred outlet and are powder coat paint finished in light grey to BS00A05 as standard.
- Plantroom units supplied with galvanised sheet steel cases, with optional powder coat paint finishes.
- Double skinned cases are standard on the FLO<sub>2</sub> size 4 & 5 belt driven units and an option on all others. Standard infill is resin bonded mineral wool slab. Heavy weight infill available for noise critical applications.
- Bolt on silencers are available for all units to both inlet and outlet.
- Unit flanges match Mez flange system.
- Drive guards available for belt drive units if required.
- Performance is guaranteed - all units tested in accordance with BS 848 Part 1. In addition, all units fall within the Building Regulations Specific Fan Power (SFP) maximum requirement of 2.0 watts/litre/second, with the general exception when the selection point is of small volume and high pressure at the top end of the fan curve. The VES Technical Department can advise the SFP at any duty.
- Units comply with all relevant European directives and are CE marked. VES Andover Limited are a company of assessed capability by BSI to the requirements of ISO9001.





## AF500 Auto-Changeover Panel Standard Features



-  Automatic changeover on airflow fail.
-  12 hour automatic duty share.
-  Duty share time memory retention during off period.
-  24 hour operation or 230v remote start/stop signal from time clock, light switch or PIR etc.
-  Zero or 15 minute run on period.
-  Volt free indication of either fan running, or common fan fail.
-  Provision for a single external fan speed controller.
-  Individual fan fuses.
-  Automatic test of both fans prior to normal running.
-  Weatherproof enclosure.



### Additional features available:

-  Fitted 7 day time clock.
-  On/off from remote 24v ac signal e.g. from BMS.
-  24v DC fire alarm shut down.

### Remote status indicator

-  Multi-coloured status indication using a single LED:

Solid green light - unit running  
 Pulsing green light - unit off  
 Red and green flashing - one fan has failed  
 Solid red light - both fans have failed

-  Simple 2 wire low voltage connection to main panel.
-  Standard single gang mounting, for internal use only.





## Direct Drive Fan Curves

### FLO<sub>2</sub> - Size 1

Direct drive fans

230 volt,  
1 phase motor

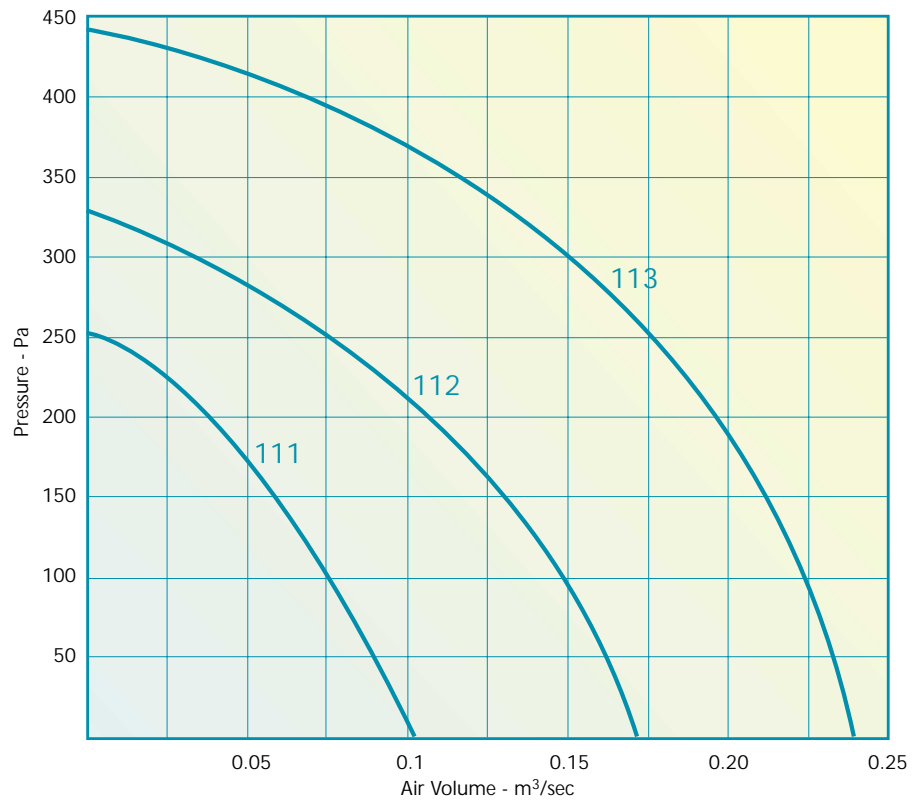

### FLO<sub>2</sub> - Size 2

Direct drive fans

230 volt,  
1 phase motor

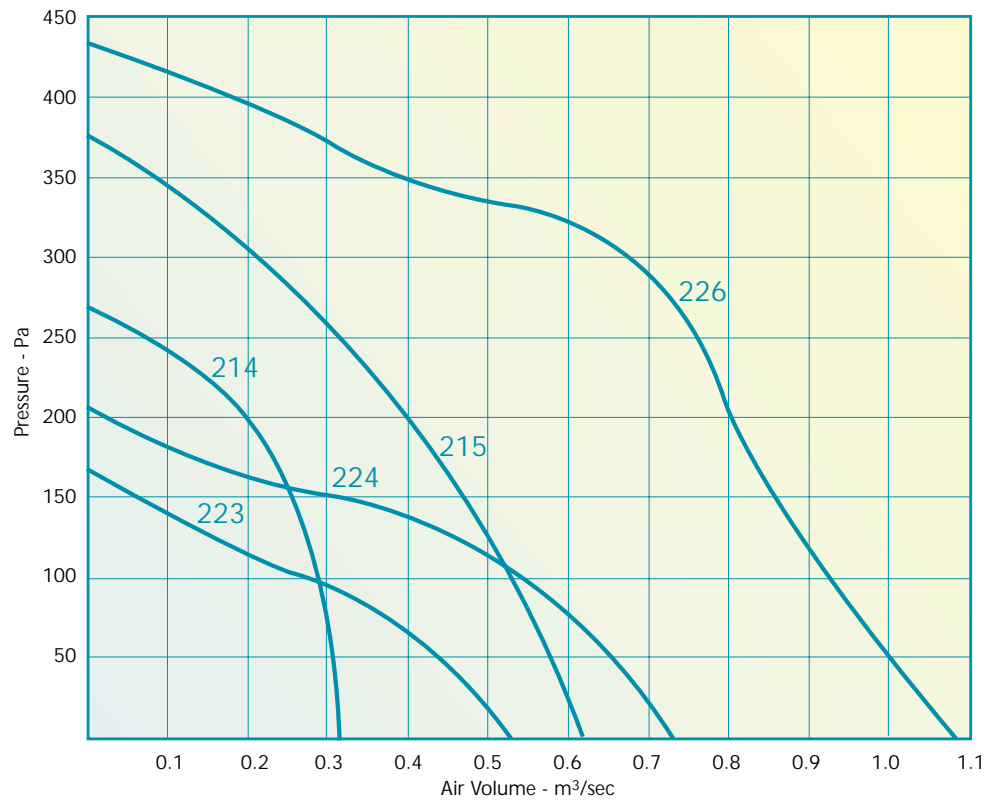



## Direct Drive Fan Curves

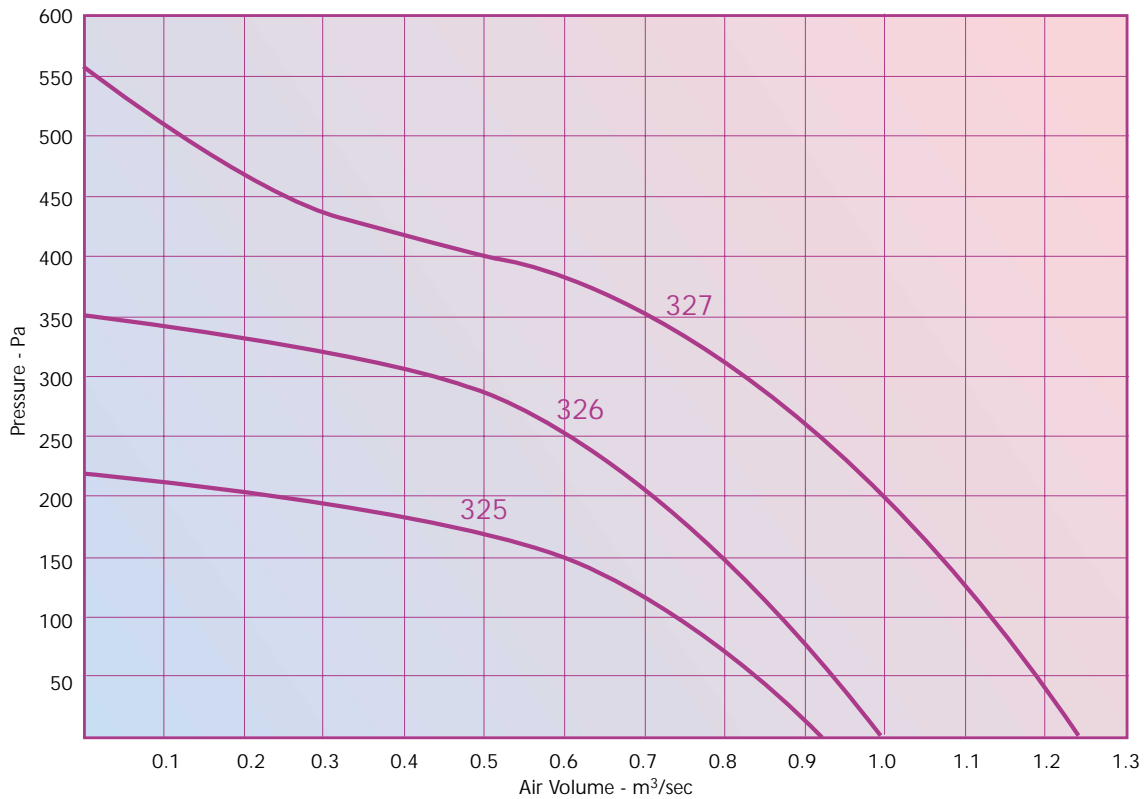

FLO<sub>2</sub> - Size 3

Direct drive fans

230 volt,  
1 phase motors

### To specify the unit you select:

- The part number adjacent to each fan curve represents the case size and fan reference:  
i.e. FLO 215  
or FLO 327  
The belt drive units on page 6 will be specified with fan speed and motor size:  
i.e. FLO 5 - 1250 / 5.5kW

To this basic part number you add the type and configuration of the case you want from the dimension pages 8 - 11:

Plant room, horizontal airflow - type PH unit becomes FLO 215 - PH.

Horizontal inlet, top outlet - type PV unit becomes FLO 5 - 1250 / 5.5kW / PV.

Double skinned case add DS.  
e.g. FLO 215 - PH / DS.





## Belt Drive Fan Curves

### FLO<sub>2</sub> - Size 4

Motors available:

400 volt 3 phase  
all sizes.  
230 volt 1 phase  
up to 2.2kW.

Specify unit  
as FLO 4 - Speed/kW/phase  
i.e. FLO 4 - 1100/2.2kW/3ph

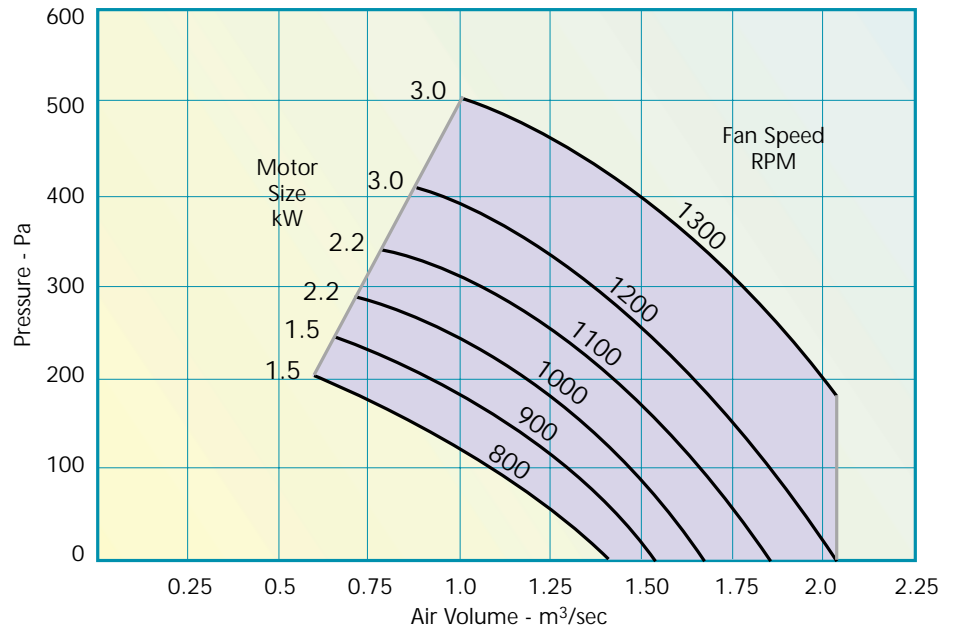

### FLO<sub>2</sub> - Size 5

All motors  
400 volt 3 phase.

Specify unit  
as FLO 5 - Speed/kW  
i.e. FLO 5 - 1250/5.5kW

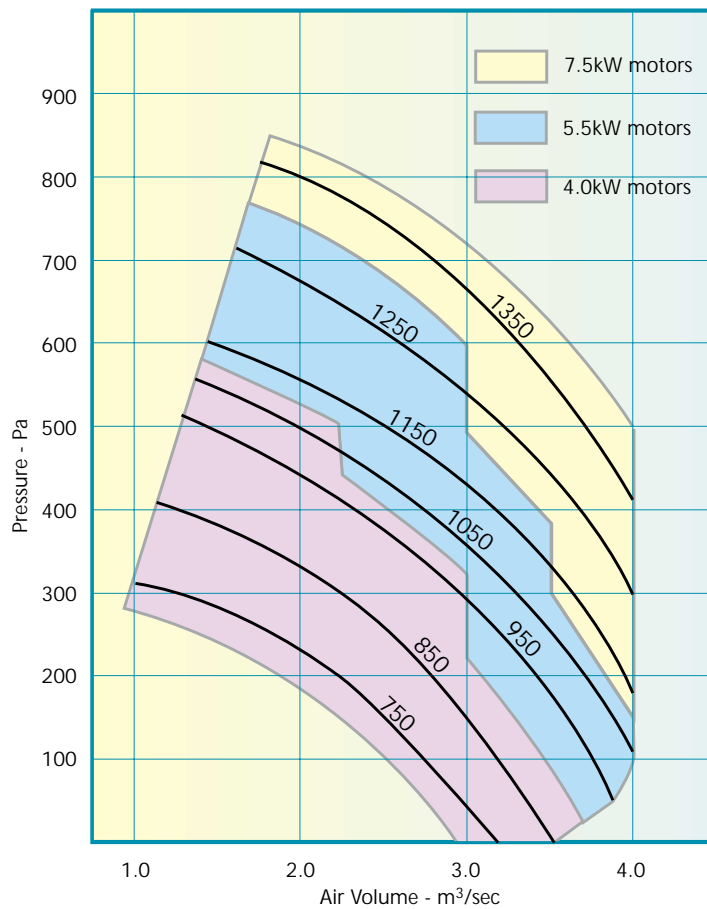

Dimensions: Pages 9 & 11.

Electrical details: Page 13.





## Constant Pressure Applications To minimise energy consumption

The FLO<sub>2</sub> is available containing fans with a built-in inverter designed for constant pressure applications.

This is ideal for minimising heat loss when a twin fan unit is to serve a hotel building with multiple bathroom/toilets, and where occupancy varies.

To match these fan units an automatic terminal is fitted in each bathroom. VES offer a choice of unit: Model BXS which is operated by an integral humidity sensor and PIR motion sensor, and model TDA which is operated by an integral PIR sensor only, and which has a manual airflow setting adjuster. The units can be installed in wall or ceiling as required.

The maximum air volume through both terminal units is 70m<sup>3</sup>/hr, and 12m<sup>3</sup>/hr in the minimum trickle vent setting. Each room unit requires a low voltage supply.

These units are easy to install and maintain and silent in operation.



Model BXS

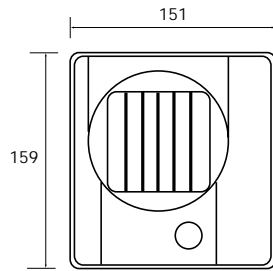

Dimensions (mm)

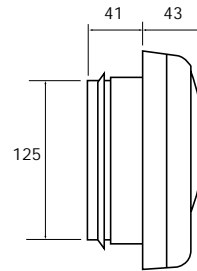

Power Supply

9 volt DC battery  
(not supplied)  
or  
230 volt via  
VES power supply unit  
type BXS PSU.



Model TDA

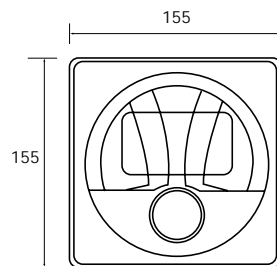

Dimensions (mm)

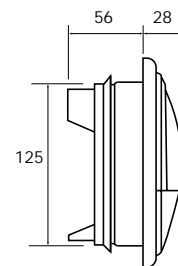

Power Supply

12 volt AC  
or  
230 volt via  
VES power supply unit  
type TDA PSU.

The fan contains a programmable inverter integral with the motor. This has an IP54 rating with class F insulation. The fan inverter is programmed at production stage to maintain the design pressure in the ducted system, reducing fan speed as demand decreases.

For weatherproof roof mounted twin fan units no additional control is required for the fan to operate. However,

for ducted units where there is considerable pressure on the fan outlet, a pressure transducer is supplied with control interface between sensor and fan inverter.

The standard AF 500 autochangeover panel is fitted to the twin fan unit.

This system is also available for the size 4 & 5 belt driven FLO<sub>2</sub> units, using separate inverters with pressure transducer and control interface.

Two sizes of the direct drive units are available. You can select any duty point from within the areas indicated.

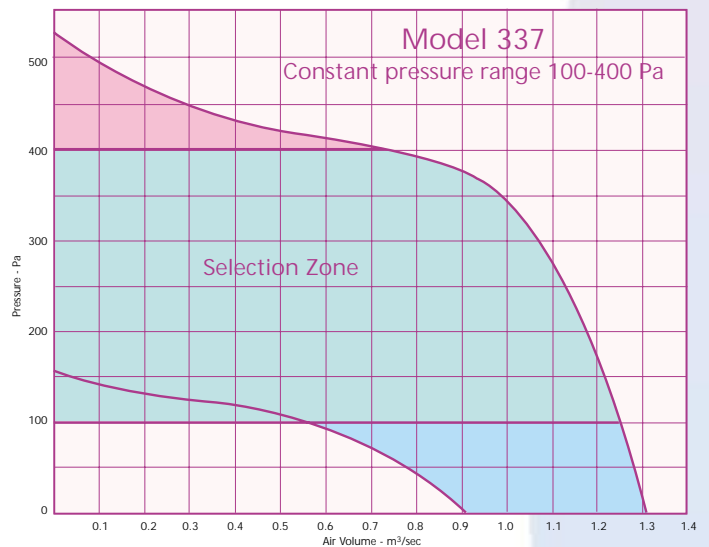
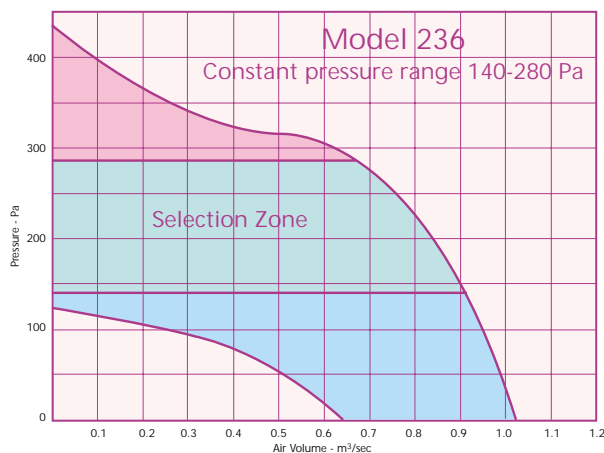



# Plantroom Units - Direct Drive Dimensions

## FLO<sub>2</sub> - Sizes 1-3 PH - Horizontal Inlet and Outlet

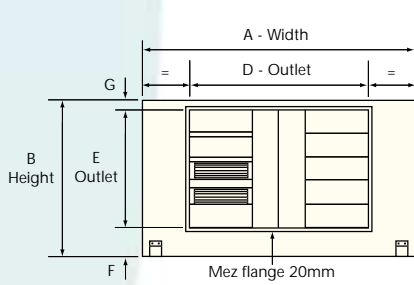

View on outlet

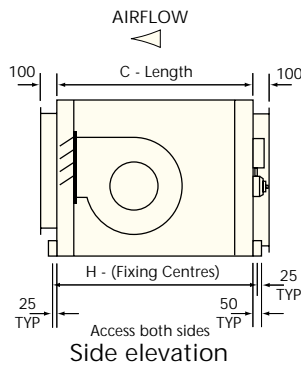

Side elevation

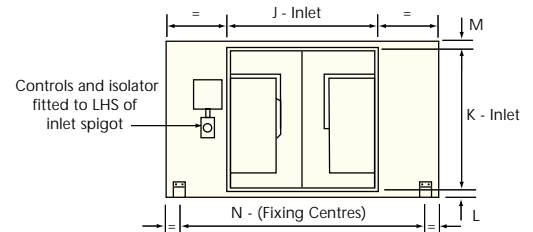

View on inlet

## FLO<sub>2</sub> - Sizes 1-3 PL - Horizontal Inlet, Top Outlet

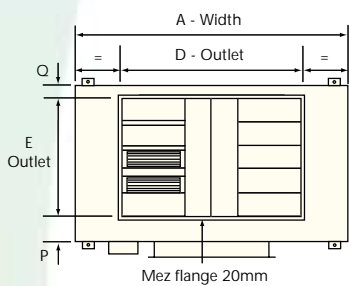

Plan view on outlet

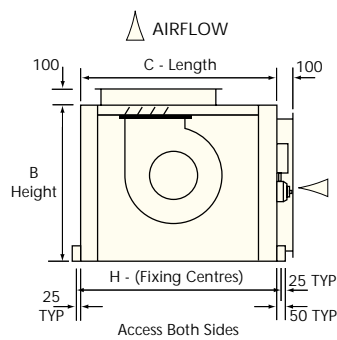

Side elevation

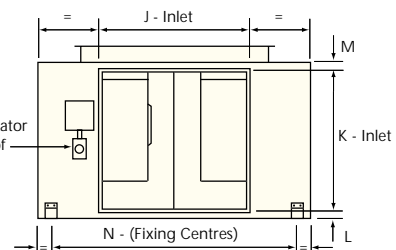

View on inlet

## FLO<sub>2</sub> - Sizes 1-3 PV - Bottom Inlet, Top Outlet

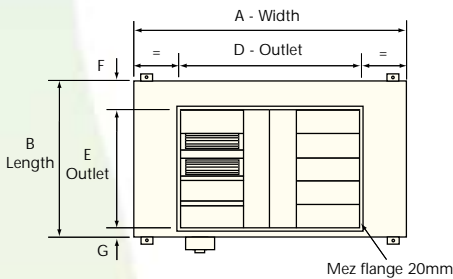

Plan view on outlet

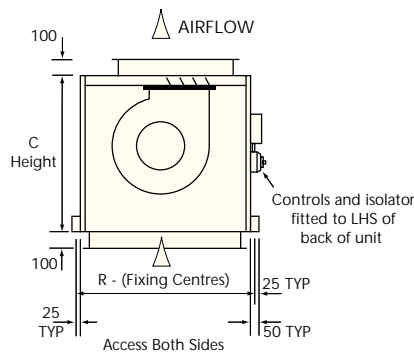

Side elevation

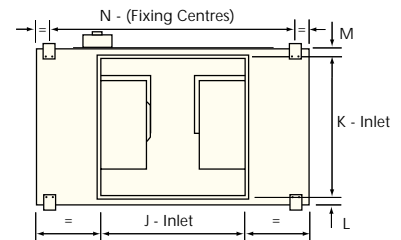

View on inlet from below

FLO <sub>2</sub>	A	B	C	D	E	F	G	H	J	K	L	M	N	P	Q	R	Weight - kg	
																	Single Skin	Double Skin
FLO 111	950	325	450	750	200	80	45	500	400	225	50	50	845	160	90	375	31	33
FLO 112	950	325	450	750	200	80	45	500	400	225	50	50	845	160	90	375	33	35
FLO 113	950	325	450	750	200	80	45	500	400	225	50	50	845	160	90	375	37	42
FLO 214	1050	550	625	850	325	110	115	675	500	450	50	50	945	135	165	600	63	72
FLO 215	1050	550	625	850	325	110	115	675	500	450	50	50	945	135	165	600	63	72
FLO 223	1050	550	625	850	325	110	115	675	500	450	50	50	945	135	165	600	65	74
FLO 224	1050	550	625	850	325	110	115	675	500	450	50	50	945	135	165	600	77	86
FLO 226	1050	550	625	850	325	110	115	675	500	450	50	50	945	135	165	600	79	88
FLO 236	1050	550	625	850	325	110	115	675	500	450	50	50	945	135	165	600	87	97
FLO 325	1150	580	675	900	400	125	55	725	600	480	50	50	1045	160	115	630	86	97
FLO 326	1150	580	675	900	400	125	55	725	600	480	50	50	1045	160	115	630	84	95
FLO 327	1150	580	675	900	400	125	55	725	600	480	50	50	1045	160	115	630	92	103
FLO 337	1150	580	675	900	400	125	55	725	600	480	50	50	1045	160	115	630	96	107

All dimensions shown are in mm.

For double skinned case add suffix DS  
i.e. FLO 226 - PL/DS

Mounting feet have an 11mm hole suitable for drop rod or floor fixing.





# Plantroom Units - Belt Drive Dimensions

## FLO<sub>2</sub> - Sizes 4 & 5 PH - Horizontal Inlet and Outlet

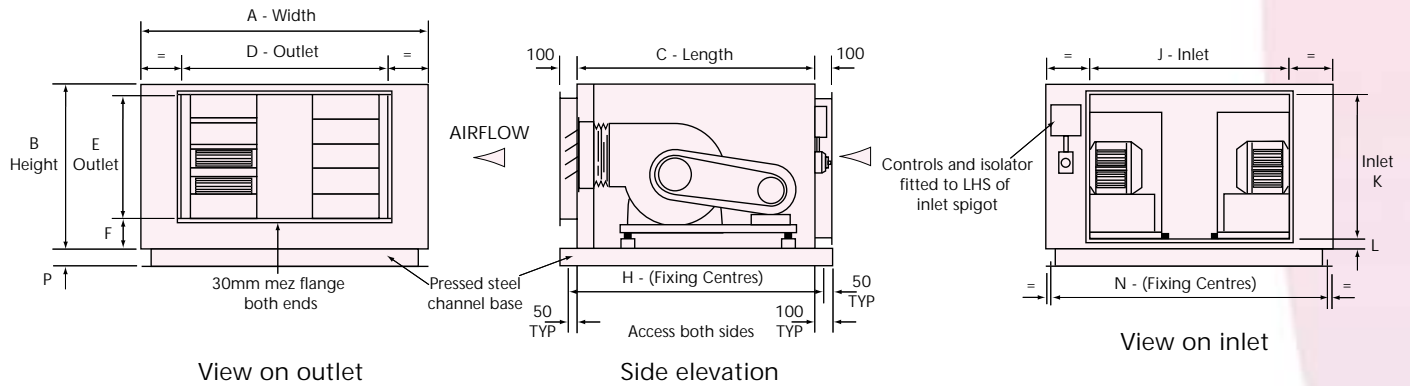

## FLO<sub>2</sub> - Sizes 4 & 5 PL - Horizontal Inlet, Top Outlet

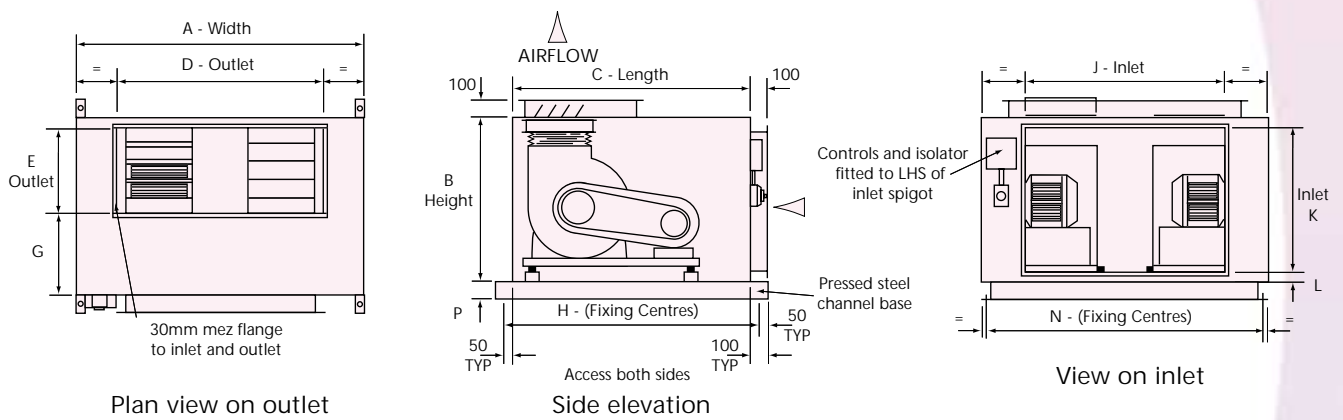

## FLO<sub>2</sub> - Sizes 4 & 5 PV - Bottom Inlet, Top Outlet

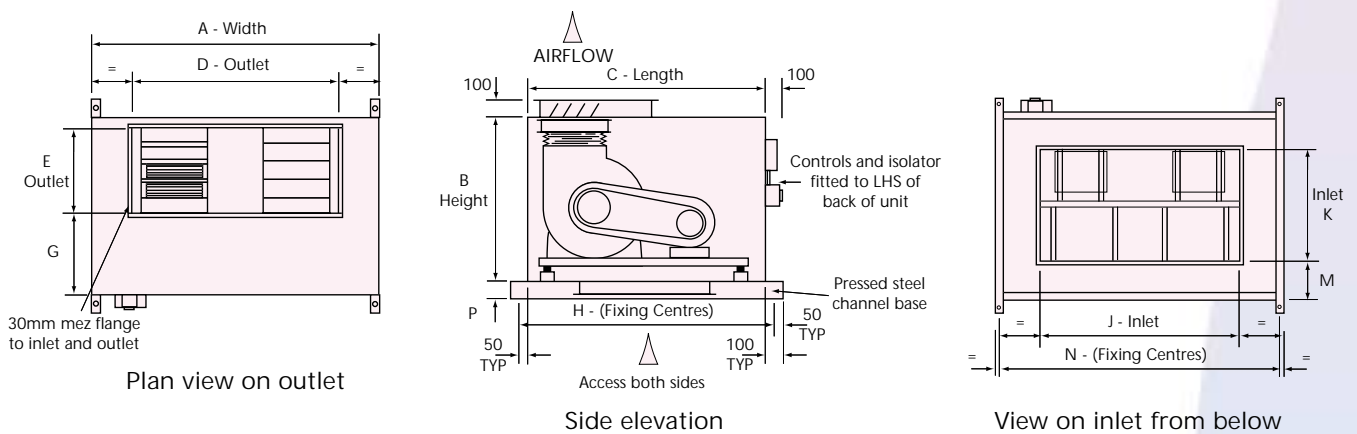

FLO <sub>2</sub> - P	A	B	C	D	E	F	G	H	J	K	L	M	N	P
Size 4	1350	750	1050	1150	500	175	485	1150	800	600	75	225	1300	75
Size 5	1800	900	1250	1400	600	225	575	1350	1250	750	75	250	1750	75

## Sizes 4 & 5 Plantroom Unit Weights

Motor size kw	Unit Weight kgs	
	Size 4	Size 5
1.5	220	-
2.2	225	-
3.0	236	-
4.0	-	348
5.5	-	390
7.5	-	408

Drive guards available for Size 4 & 5 FLO<sub>2</sub> units if required.  
FLO<sub>2</sub> size 4 & 5 cases are double skinned as standard.





# Weatherproof Units - Direct Drive Dimensions

## FLO<sub>2</sub> - Sizes 1-3 WH - Horizontal Inlet

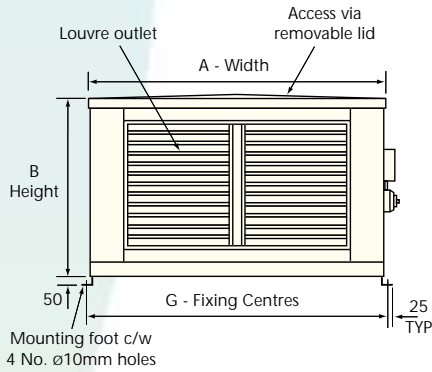

View on outlet

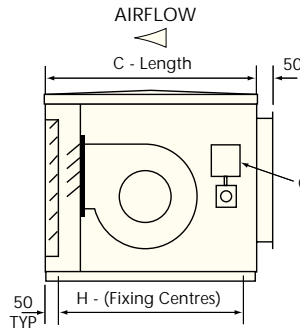

Side elevation

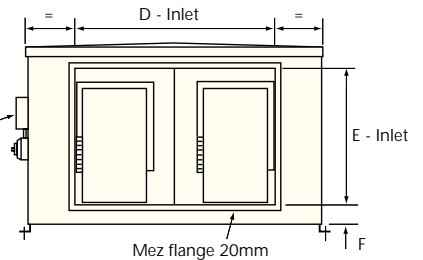

View on inlet

## FLO<sub>2</sub> - Sizes 1-3 WL - Bottom Inlet, Curb Mounting

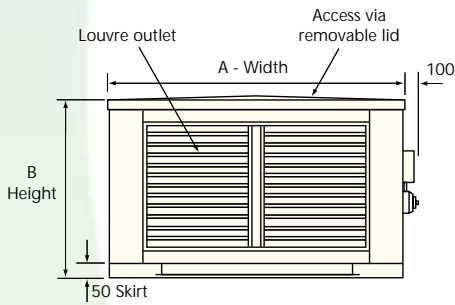

View on outlet

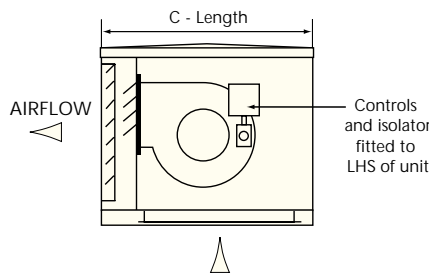

Side elevation

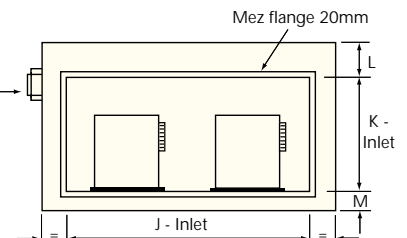

View on inlet (from below)

### Curb Detail

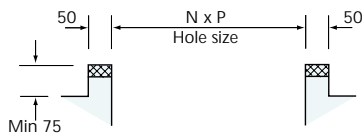

*FLO <sub>2</sub>	A	B	C	D	E	F	G	H	J	K	L	M	N	P	Weight - kg	
															Single Skin	Double Skin
FLO 111	850	410	550	400	225	100	900	450	400	225	125	200	700	400	31	33
FLO 112	850	410	550	400	225	100	900	450	400	225	125	200	700	400	33	35
FLO 113	850	410	550	400	225	100	900	450	400	225	125	200	700	400	37	42
FLO 214	1050	570	750	500	450	60	1100	650	500	450	115	185	900	540	56	59
FLO 215	1050	570	750	500	450	60	1100	650	500	450	115	185	900	540	56	59
FLO 223	1050	570	750	500	450	60	1100	650	500	450	115	185	900	540	58	66
FLO 224	1050	570	750	500	450	60	1100	650	500	450	115	185	900	540	70	78
FLO 226	1050	570	750	500	450	60	1100	650	500	450	115	185	900	540	72	80
FLO 236	1050	570	750	500	450	60	1100	650	500	450	115	185	900	540	80	88
FLO 325	1150	610	800	600	480	70	1200	700	600	480	145	175	1000	600	83	92
FLO 326	1150	610	800	600	480	70	1200	700	600	480	145	175	1000	600	81	91
FLO 327	1150	610	800	600	480	70	1200	700	600	480	145	175	1000	600	89	98
FLO 337	1150	610	800	600	480	70	1200	700	600	480	145	175	1000	600	93	103

All dimensions shown are in mm.

\* Add designation to model i.e. FLO 111 - WH  
or FLO 111 - WL

For double skinned case add suffix DS  
i.e. FLO 327 - WL/DS





# Weatherproof Units - Belt Drive Dimensions

## FLO<sub>2</sub> - Sizes 4 & 5 WH - Horizontal Inlet

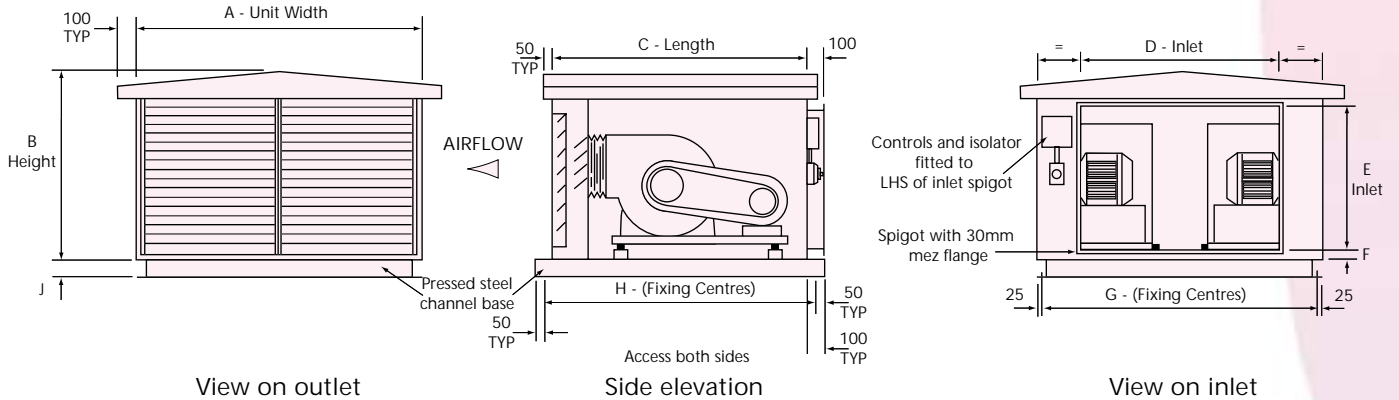

## FLO<sub>2</sub> - Sizes 4 & 5 WL - Bottom Inlet, Curb Mounting

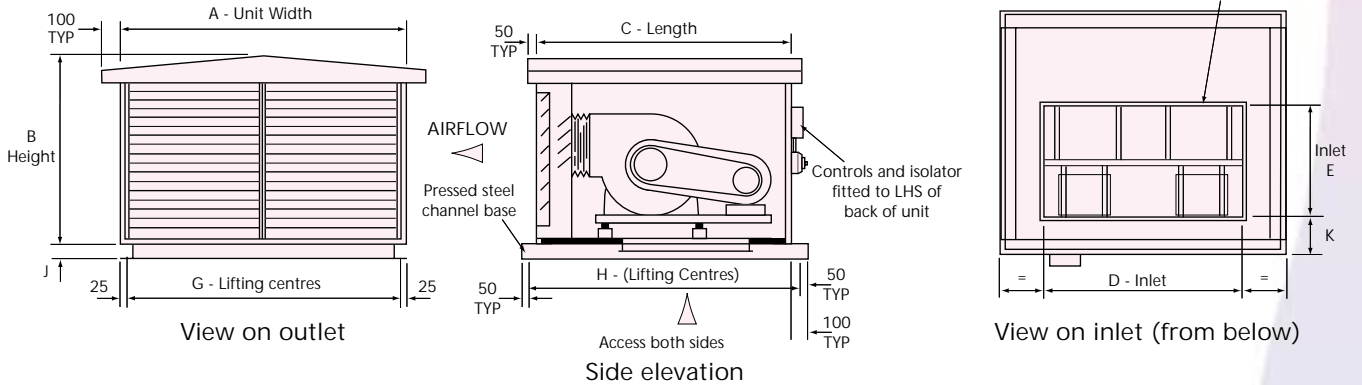

### Curb Detail

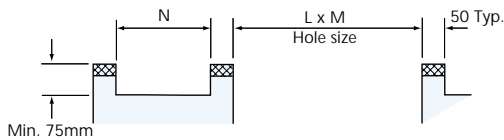

FLO <sub>2</sub> - W	A	B	C	D	E	F	G	H	J	K	L	M	N
Size 4	1350	850	1275	800	600	75	1300	1375	75	225	750	950	175
Size 5	1800	1025	1550	1250	750	75	1750	1650	75	250	900	1400	225

## Sizes 4 & 5 Weatherproof Unit Weights

Motor size kw	Unit Weight kgs	
	Size 4	Size 5
1.5	265	-
2.2	270	-
3.0	285	-
4.0	-	418
5.5	-	468
7.5	-	490

Drive guards available for Size 4 & 5 FLO<sub>2</sub> units if required.  
FLO<sub>2</sub> size 4 & 5 cases are double skinned as standard.





## Sound Data

### Sound Power Level dB ref 10<sup>-12</sup> Watts PWL

FLO <sub>2</sub> Unit Size	Centre Frequency - Hz								SPL dBA*
	63	125	250	500	1k	2k	4k	8k	
111	73	64	59	59	66	65	64	64	54
112	72	65	59	63	70	68	67	66	57
113	76	74	69	70	73	70	69	69	61
223	69	66	59	58	58	56	54	50	47
214	75	72	68	63	70	67	66	67	58
224	69	70	64	69	69	57	65	61	58
215	78	77	76	76	79	77	75	77	67
226/236	75	76	70	72	75	75	73	67	64
325	71	70	64	68	69	57	66	60	58
326	75	76	70	72	75	75	73	67	64
327/337	73	75	68	72	74	73	70	65	62
4 - 800	72	71	68	66	65	63	59	55	55
4 - 900	74	73	70	68	67	65	61	57	57
4 - 1000	77	76	73	71	70	68	64	60	60
4 - 1100	80	79	76	74	73	71	67	63	63
4 - 1200	82	81	78	76	75	73	69	65	65
4 - 1300	84	83	80	78	77	75	61	67	67
5 - 750	79	78	75	73	72	70	66	62	59
5 - 850	81	80	77	75	74	72	68	64	61
5 - 950	83	82	79	77	76	74	70	66	63
5 - 1050	85	84	81	79	78	76	72	68	65
5 - 1150	87	86	83	81	80	78	74	70	67
5 - 1250	89	88	85	83	82	80	76	72	69
5 - 1350	91	90	87	85	84	82	78	74	71

\* SPL, dBA is a guide figure at 3 metres from outlet, free field.

## Noise Breakout

### Sound Pressure Levels SPL: dBA and NR levels

FLO <sub>2</sub> Unit Size	Single Skin Case				Double Skin Case			
	dBA @1m	NR @1m	dBA @3m	NR @3m	dBA @1m	NR @1m	dBA @3m	NR @3m
111	40	35	30	25	35	30	25	25
112	42	40	32	30	37	35	27	25
113	47	45	37	35	42	40	32	30
223	40	35	35	30	35	30	30	25
214	45	40	35	30	40	35	30	25
224	51	45	46	40	46	40	41	35
215	52	50	42	40	47	45	37	35
226/236	57	55	52	50	52	50	47	45
325	51	45	46	40	46	40	41	35
326	57	55	52	50	52	50	47	45
327/337	55	50	50	45	50	45	45	40
4 - 800	-	-	-	-	45	40	40	35
4 - 900	-	-	-	-	50	45	43	38
4 - 1000	-	-	-	-	52	47	45	40
4 - 1100	-	-	-	-	55	50	48	43
4 - 1200	-	-	-	-	57	52	50	45
4 - 1300	-	-	-	-	59	54	52	47
5 - 750	-	-	-	-	48	45	43	40
5 - 850	-	-	-	-	50	47	45	42
5 - 950	-	-	-	-	52	49	47	44
5 - 1050	-	-	-	-	54	51	49	46
5 - 1150	-	-	-	-	56	53	51	48
5 - 1250	-	-	-	-	58	55	53	50
5 - 1350	-	-	-	-	60	57	50	52





# FLO<sub>2</sub> Electrical Details

FLO <sub>2</sub> Model	Motor Output Watts	Voltage/Phase	FLC Amps Max.	Fan Speed	VES Fan Ref	Speed Controller	
						Transformer	Electronic
111	120	230-1	0.55	1510	AL 121	T1-E	-
112	245	230-1	1.10	1540	AL 221	T1-E	-
113	350	230-1	1.45	1800	AL 321	T4-E	V20-E
223	320	230-1	1.60	920	GZ 361	T1-E	-
214	460	230-1	2.10	1280	AL 441	T4-E	V20-E
224	525	230-1	2.47	900	GZ 461	T4-E	V65-E
215	675	230-1	3.15	1380	AL 541	T4-E	V65-E
226	1310	230-1	5.70	1380	GZ 641	T8-E	V65-E
236	Variable	230-1	5.20	Variable	GZ 641/I	N/A	N/A
325	661	230-1	3.10	900	GZ 561	T4-E	V65-E
326	1150	230-1	5.10	1380	GZ 641	T8-E	V65-E
327	1650	230-1	7.20	1380	GZ 741	T8-E	-
337	Variable	230-1	9.00	Variable	GZ 741/I	N/A	N/A
4-800	1.5kW	400-3	3.60	800	TLZ 280R	-	Inverter
4-900	1.5kW	400-3	3.60	900	TLZ 280R	-	Inverter
4-1000	2.2kW	400-3	5.30	1000	TLZ 280R	-	Inverter
4-1100	2.2kW	400-3	5.30	1100	TLZ 280R	-	Inverter
4-1200	3.0kW	400-3	6.80	1200	TLZ 280R	-	Inverter
4-1300	3.0kW	400-3	6.80	1300	TLZ 280R	-	Inverter
5-750	4.0kW	400-3	9.20	750	TLZ 355R	-	Inverter
5-850	4.0kW	400-3	9.20	850	TLZ 355R	-	Inverter
5-950	4.0kW	400-3	9.20	950	TLZ 355R	-	Inverter
5-950	5.5kW	400-3	11.40	950	TLZ 355R	-	Inverter
5-1050	4.0kW	400-3	9.20	1050	TLZ 355R	-	Inverter
5-1050	5.5kW	400-3	11.40	1050	TLZ 355R	-	Inverter
5-1150	5.5kW	400-3	11.40	1150	TLZ 355R	-	Inverter
5-1150	7.5kW	400-3	14.80	1150	TLZ 355R	-	Inverter
5-1250	5.5kW	400-3	11.40	1250	TLZ 355R	-	Inverter
5-1250	7.5kW	400-3	14.80	1250	TLZ 355R	-	Inverter
5-1350	7.5kW	400-3	14.80	1350	TLZ 355R	-	Inverter

FLO<sub>2</sub> units are ideal for use with the VES Energy Saver fan control unit.

## Electrical Connections

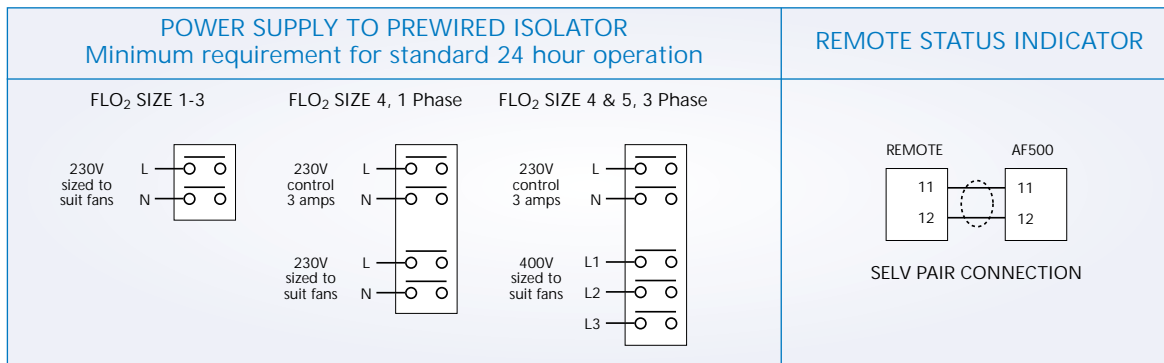

Additional features if required

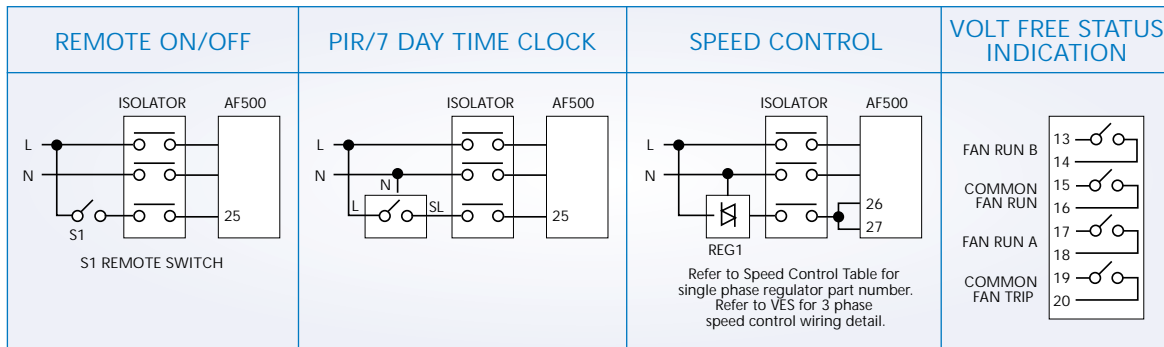



## Silencers

### Inlet (Room Side) Model FAI

Designed to fit directly onto all configurations of plantroom unit, and horizontal inlet weatherproof units.

### Silencer Air Pressure Loss

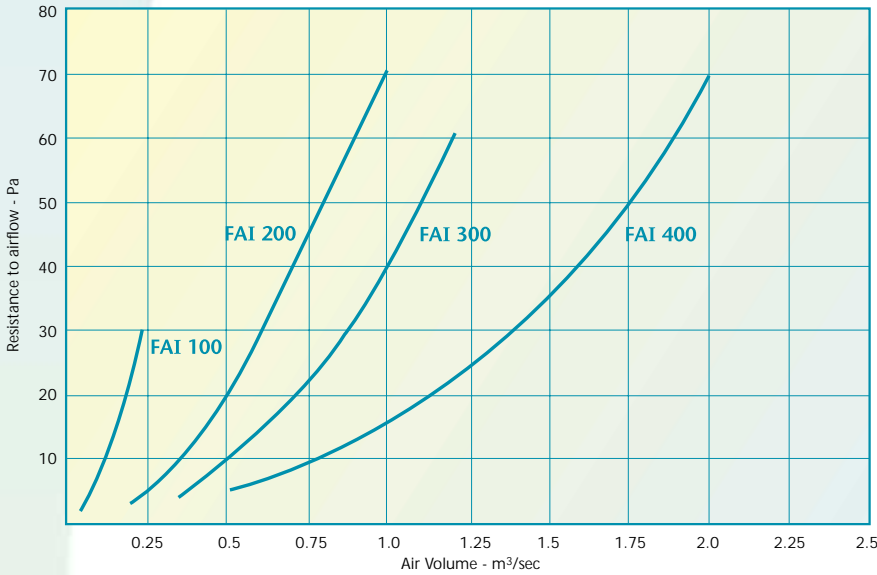

### FLO<sub>2</sub> - Size 1-4

Inlet (Room Side) Silencers for FLO<sub>2</sub> units size 1-4

Plantroom and weatherproof units

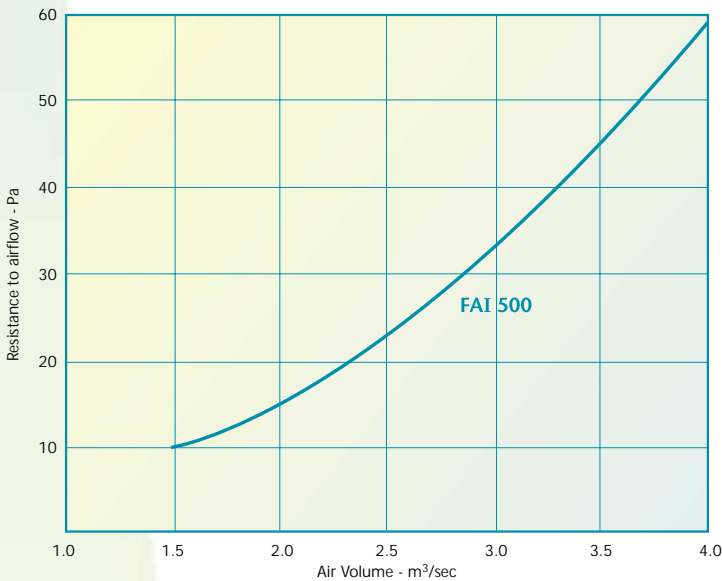

### FLO<sub>2</sub> - Size 5

Inlet (Room Side) Silencers for FLO<sub>2</sub> units size 5

Plantroom and weatherproof units

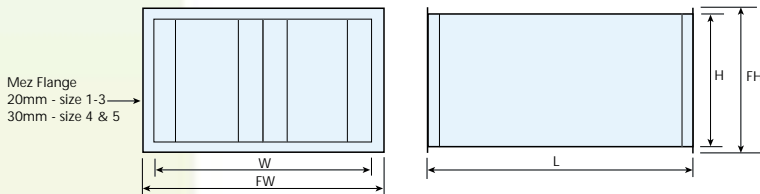

### Dimensions

Silencer Model	To Fit Size	Dimensions - mm					Weight kg
		W	H	L	FW	FH	
FAI 100	1	400	225	750	440	265	14
FAI 200	2	500	450	1000	540	490	30
FAI 300	3	600	480	1000	640	520	42
FAI 400	4	800	600	1200	860	660	80
FAI 500	5	1250	750	1200	1310	810	101

### Attenuation - Insertion Loss, dB

Silencer Model	Centre Frequency - Hz							
	63	125	250	500	1k	2k	4k	8k
FAI 100	4	5	7	16	24	27	20	18
FAI 200	5	6	10	17	26	28	21	19
FAI 300	5	7	12	25	32	32	23	19
FAI 400	6	12	23	40	50	50	40	29
FAI 500	5	9	19	33	42	42	30	20





## Silencers

### Outlet (to Atmosphere) Model FAO

Designed to fit directly onto the outlet of all configurations of plantroom units.

### Silencer Air Pressure Loss

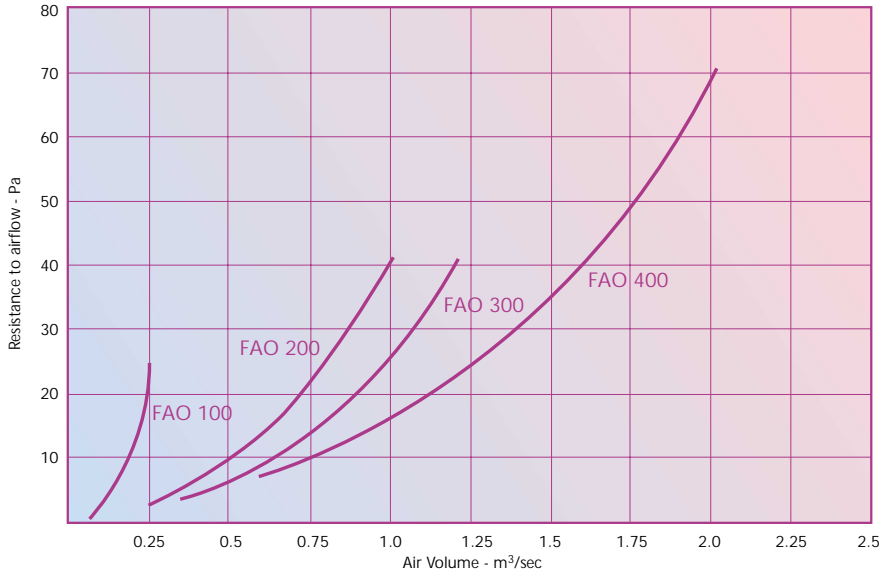

### FLO<sub>2</sub> - Size 1-4

Outlet (To Atmosphere)  
Silencers for FLO<sub>2</sub> units  
size 1-4

Plantroom units only\*

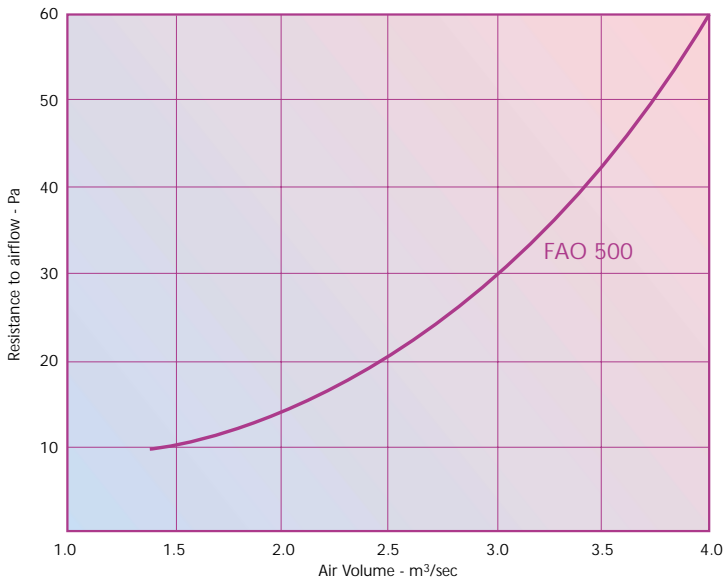

### FLO<sub>2</sub> - Size 5

Outlet (To Atmosphere)  
Silencer for FLO<sub>2</sub> unit size 5

Plantroom unit only\*

### Dimensions

Silencer Model	To Fit Size	Dimensions - mm					Weight kg
		W	H	L	FW	FH	
FAO 100	1	750	200	750	790	240	20
FAO 200	2	850	325	1000	890	365	35
FAO 300	3	900	400	1000	940	440	45
FAO 400	4	1150	500	1200	1210	560	90
FAO 500	5	1400	600	1200	1460	660	99

### Attenuation - Insertion Loss, dB

Silencer Model	Centre Frequency - Hz							
	63	125	250	500	1k	2k	4k	8k
FAO 100	4	5	7	16	24	27	20	18
FAO 200	5	6	10	17	26	28	21	19
FAO 300	5	7	12	25	32	32	23	19
FAO 400	6	12	23	40	50	50	40	29
FAO 500	5	9	19	33	42	42	30	20

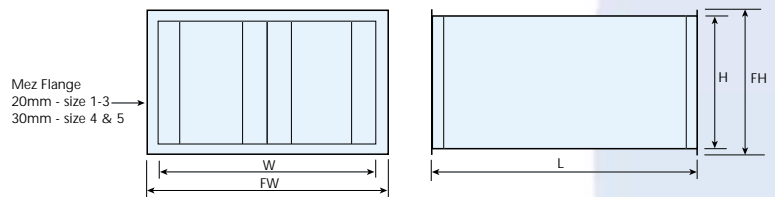

\*Outlet silencers for weatherproof units can be supplied to fit directly to units. The louvre will be omitted. Silencer will be powder coat paint finished to match FLO<sub>2</sub> unit. Outlet cowl and support foot will be provided.





## Specification Quality Standards

VES Andover Limited is a company of assessed capability by BSI to the requirements of ISO 9001. All units have been tested in accordance with BS 848 part 1. Units comply with all relevant European directives and are CE marked.



ISO 9001-2000  
Cert. No. Q5375

### Fans

Each unit contains two no. forward curved multi-vane double inlet double width centrifugal fans.

FLO<sub>2</sub> standard units size 1-3 contain fans that are direct driven by hub mounted motors. They have high temperature automatic cut-out protection, and can be speed controlled using VES speed regulators. Size 1-3 have 230 volt 1 phase 50Hz motors. The constant pressure units models 236 and 337 have built-in inverters. These also run on a 230 volt 1 phase supply. These fans are programmed at VES to a standard setting and can be easily adjusted on site, after which they are automatic in operation.

FLO<sub>2</sub> size 4 & 5 units contain fans belt driven by squirrel cage induction motors, 400 volt, 3 phase, 50Hz, totally enclosed, fan cooled, with top mounted terminal box. 230 volt 1 phase motors available in FLO<sub>2</sub> size 4 units up to 2.2kW. All are class F rating, EFF2 efficiency, and insulated to IP55. The minimum two belt drive is pre-aligned and tensioned at VES works.

All fans and motors are fully vibration isolated inside the unit from the FLO<sub>2</sub> case. Additional external AV mounts and flexible connections are not required.

### Auto-changeover System

An AF500 auto-changeover panel is fitted and pre-wired to each FLO<sub>2</sub> unit. Each unit has airflow operated micro switches which signal air flow failure to the AF500. The remote twin fan unit status indicator requires two wire low voltage connection to the AF500, using screened or twisted pair cable.

Refer to page 3 for full details of AF500 auto-changeover unit.

Each unit has a fitted and pre-wired isolator.

### Case - Plantroom units

The FLO<sub>2</sub> sizes 1-3 have single skinned cases as standard constructed using galvanised steel sheet. Options include

double skinned construction and external powder coat paint finish in light grey to BS 00A05 or to your colour choice by special order.

The fitted mounting feet can be used to hang the unit with drop rods or screw down onto a base.

Double skinned cases in galvanised sheet steel are standard on the FLO<sub>2</sub> size 4 & 5 units, with powder coat finish as an option.

All unit flanges match the Mez flange system.

Refer to dimension pages for maintenance access and connection details.

### Case - Weatherproof Units

All weatherproof units are manufactured in galvanised sheet steel and externally powder coat finished in light grey to BS 00A05 as standard or to your colour choice by special order.

The direct drive FLO<sub>2</sub> size 1-3 units have louvred outlets. These units are single skin as standard with option of double skin construction.

The belt drive weatherproof FLO<sub>2</sub> size 4 & 5 are double skinned as standard.

Access into weatherproof FLO<sub>2</sub> units is via a removable lid on sizes 1-3 and side access panels on size 4 & 5.

### Silencers

Silencer construction is lock formed galvanised sheet steel case with Mez flanges. Splitters have a galvanised sheet steel frame with non combustible resin bonded mineral fibre slab infill, faced with bonded glass tissue to prevent erosion of attenuating material.

These are available for inlet and outlet, plantroom and weatherproof. Standard silencer performance data is detailed on pages 14 & 15, non standard silencers are built to order. We recommend that weatherproof silencers are specified with a light grey powder coat paint finish to BS 00A05, with supporting base and outlet cowl specified for outlet silencers.



*Go with a FLO*

VES Andover Limited  
Eagle Close, Chandlers Ford Industrial Estate,  
Chandlers Ford, Eastleigh, Hampshire SO53 4NF

Tel: 08702 40 43 40  
Fax: 08702 40 45 50  
e-mail: vesltd@ves.co.uk  
www.ves.co.uk

VES reserve the right to amend product specifications and details without notice.



© 2005 VES Andover Ltd.  
Issue 2 - 05/2005