

roundfan

inline centrifugal fans

Operation & Maintenance Manual



Eagle Close, Chandlers Ford Industrial Estate, Chandlers Ford, Eastleigh, Hampshire, SO53 4NF

Tel: +44 (0) 2380 46 11 50

email: info@ves.co.uk

web: www.ves.co.uk

VES Ref. ID. 617
Issue F
December 2022
Original Instructions

Conventions

Important  **This manual must be read in full before Installation, Operation and Maintenance of the units supplied**

Please ensure that this document is passed to the end user. This manual forms an integral part of the product and should be kept for the working life of the product. Additional copies of this and supporting documents are available by contacting VES or by visiting www.ves.co.uk and following the 'Download O & M's' link.

The following symbols used within this document refer to potential dangers, advice for safe operation or important points of reference

Warning  Indicates hazards associated with electric current and high voltages

Caution  Indicates hazards that require safety advice for personnel or potential unit/property damage

Important  Indicates important information

Contents	1	Introduction	page 2
	2	Nomenclature	3
	3	Receipt of Goods & Handling	3
	4	Installation	3
	5	Standard Wiring & Fan Installation	6
	6	Maintenance	10

Introduction **1** The **roundfan** series is a range of inline EC centrifugal fans available sizes from 100 mm to 315 mm diameter, with a duty range up to 0.38 m³/s. The standard operating temperature for AC units is -25 to +45 °C <95% RH.

For further technical details regarding dimensions and weights, contact VES on **02380 46 11 50**, quoting the sales order (SO) number and the unit type as found on the unit nameplate, or alternatively visit www.ves.co.uk.

Nomenclature	2	Point Description	Point Variants	Details (as appropriate)
Part Number Coding	1	Product	R	In-line Round Fans
	2	Case Type	S M	Plastic Cased Metal Cased
	3	Connection Spigot Diameter	100... 315	Sequential see unit outline for details
	4	Motor Type	/Null /EC	AC Motor EC Motor

Typical Example RM160/EC

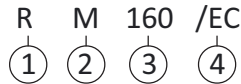

Receipt of Goods & Handling **3** Immediately upon receipt of goods, check for possible damage in transit paying particular attention to fan impellers and casework. Prior to installation please check to ensure alignment and smooth rotation of the impeller after transit. Also check to ensure that any ancillary items are included. These will normally be supplied fitted or, in the case of small items, taped to the unit.
In the event of any damage having occurred or if any item is found to be missing, it is essential to inform VES Andover Ltd. within **7 days** of delivery quoting sales order number and the unit type, as found on the unit nameplate. After this period, VES would be unable to accept any claim for damaged or missing goods.

Installation **4** The entire system must be considered for safety purposes and it is the responsibility of the installer to ensure that all of the equipment is installed in compliance with the manufacturer’s recommendations, with due regard to the current HEALTH AND SAFETY AT WORK ACT and conforms to all relevant statutory regulations.
Where a unit is installed so that a failure of components could result in injury to personnel, precautions should be taken to prevent such an injury. Maintenance must be provided in accordance with Health and Safety and Building Regulations. For confirmation of required access please see the appropriate unit outline drawing.

For optimum unit performance, careful consideration must be paid to the location of the unit in relation to the ductwork and associated items; placing the unit directly adjacent to a bend in ductwork will impede airflow and reduce performance. Consideration should be given by the installer to ensure adequate illumination of the unit location in order for safe maintenance. Further consideration should be given to the unit’s position and secured into place as appropriate. This is especially important with external units as the wind and elements may effect the overall stability of the unit.

Important If the unit is installed where there is a reasonable possibility of persons or objects coming into contact with the impeller whilst operational, a guard should be fitted or steps taken to prevent this. It is the installer’s responsibility to ensure that access is not obstructed in any way and safe working access is provided.

Installation 4 Continued

Unit mounting options

Fig. 1 2 3 4

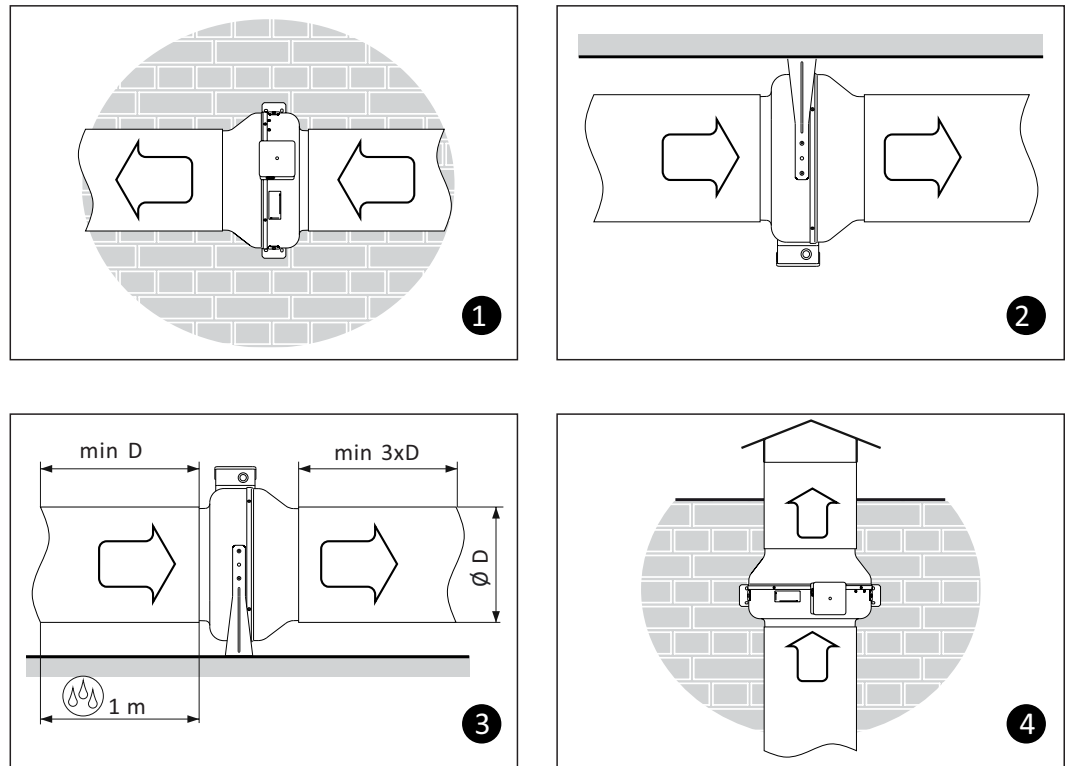

The **roundfan** is designed for horizontal or vertical mounting. Airflow in the system must be in the direction as shown on the fan casing. When installing in a vertical configuration it is the installer's responsibility to fit an appropriate weather cowl to prevent water ingress. It is also recommended that a suitable drain should be incorporated into the adjoining ductwork to reduce the likelihood of water contamination in the event of rainwater entering the ductwork. The **roundfan** is designed to fit directly inline of a tube system. It is recommended that the unit be held in position with padded fast clamps to reduce noise breakout and vibration. Alternative (permanent) fixings can be used but are likely to cause noise breakout and vibration, inspection and cleaning of the unit will be harder to implement. Additional support is available particularly for the larger units, by means of optional mounting feet. Where provided spigots should not be used to support the ductwork and used solely as a means of ductwork connection.

Caution  These fans are not suitable for use in explosive or fire-hazardous environments

All of the components are fitted inline with the fan and ductwork. For externally mounted units, it is essential that the casing is positioned so as to orientate the terminal box on the underside of the unit. This will ensure that surface water runs away from the terminal box and off the unit. To ensure that waterproofing is achieved by the unit silicone should be run around the join in the casing and terminal box. In situations of especially high humidity, provide a straight air duct section at least 1 metre long on the intake spigot side for fans mounted in the horizontal position.

Standard Wiring 5 & Fan Installation

Warning ⚡ The electrical supply **must be fully isolated** before attempting to affect any work on this unit. All electrical connections to any unit must be carried out in accordance with the current edition of the I.E.E Regulations, only competent Electricians should be allowed to affect any electrical work to our units.

Important ! It is the responsibility of the installer to ensure that a suitable cable gland (giving adequate protection and strain relief) is fitted, and in doing so also ensure that no internal components are damaged during this installation. It is the customer's responsibility to supply earth fault protection through the building installation device and a dedicated, isolated power supply with overload protection.

Warning ⚡ Do not connect any unit to an electrical supply voltage outside of the specification.

Standard Fan Details 230 VAC 50Hz (RM - EC Model)

Fig. 5

Model	230 V 1PH 50Hz		Speed (rpm)
	Motor Power (W)	F.L.C (A)	
RM100/EC	90	0.70	3250
RM150/EC	107	0.89	3060
RM160/EC	108	0.90	3030
RM200/EC	83	0.63	2500
RM250/EC	164	1.15	2900
RM315/EC	164	1.15	2900

Standard wiring arrangement 230 VAC 50Hz (RM - EC Model)

Fig. 6

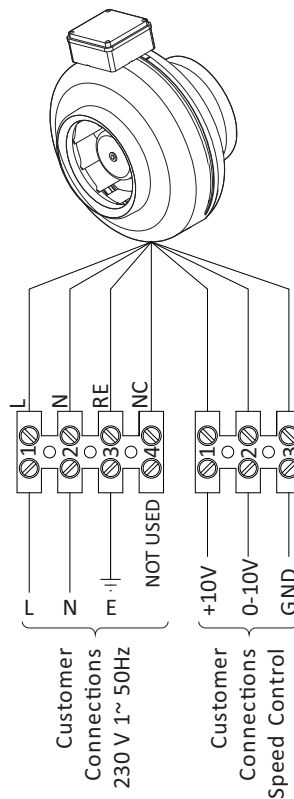

Important ! For associated components (speed controllers, controls) please refer to the relevant accompanying O&M. To comply with ErP 2018 it is necessary to use a local demand control typology.

Maintenance 6

Important 

Before attempting to carry out any work on our units, all accompanying documentation including warning labels on the unit must be referenced. Should it be necessary to remove any component ensure that these are secured into position once reinstalled. It is critical that after any maintenance work has been conducted that all components removed/replaced be refitted correctly by a competent engineer.

Warning 

Before attempting to carry out any maintenance work, investigative or repair work on our units, the unit **MUST BE COMPLETELY ISOLATED** from its electrical supply. Ensure a minimum of two minutes after electrical disconnection before removing access panels. This will allow any moving parts to come to a rest. Care should also be taken when accessing external units as the wind and elements may cause moving parts to 'windmill'.

Recommended Checks

In general, this series of units require little maintenance. In the unlikely event of component failure, spares are available from stock at VES Andover Ltd.

Three Monthly Checks

Check inside the unit for accumulation of dust, grease etc. If the fan impellor is heavily soiled, clean out carefully by hand (ensure the unit is properly isolated). Failure to do this periodically could lead to a loss of performance or the fan to become out of balance, leading ultimately to bearing failure.

Cleaning details

Fig. **7 8 9 10 11 12**

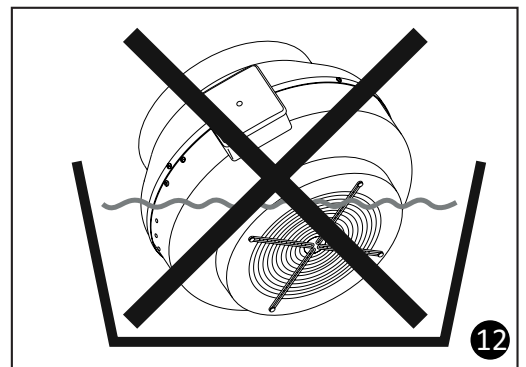
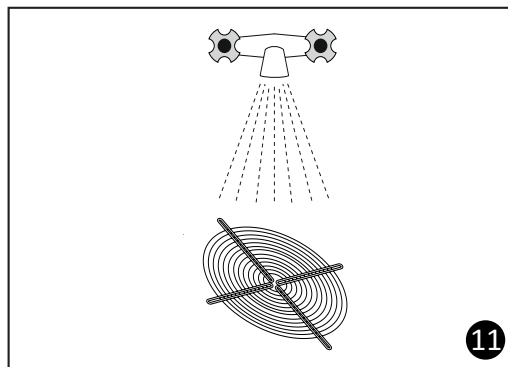
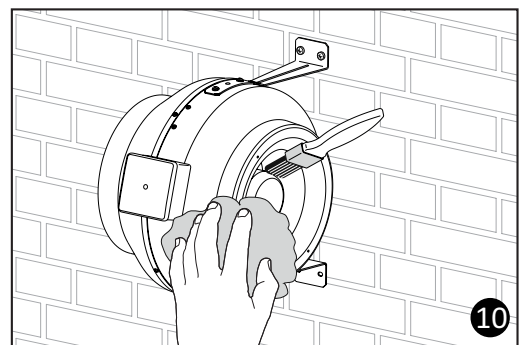
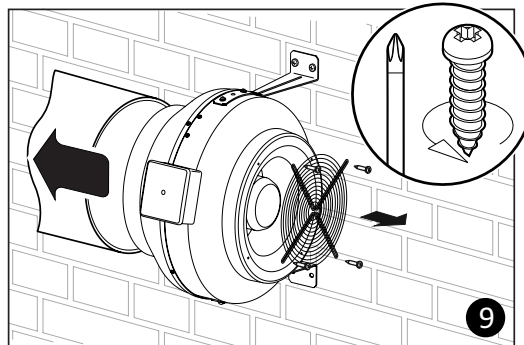
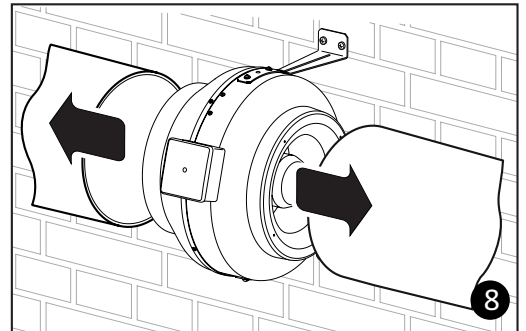
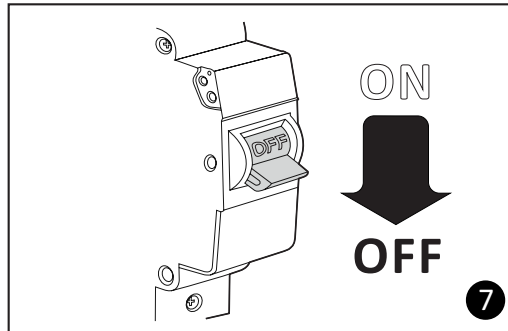

Maintenance 6 Continued**Maintenance 6 Continued****Six Monthly Checks**

roundfans used in a supply system usually have a filter box, with a disposable filter. Every few months inspect the filters, if the filter is heavily soiled replace accordingly. To inspect or replace a filter, simply remove the filter box lid to gain access to the filter.

Depending on the unit configuration: Inspect and clean if necessary electric heaters, silencers, screen guards and wall shutters. By doing so regularly performance will be maintained.

To gain access to the fan for inspection, maintenance and repairs: remove padded fast clamp (or permanent fixings) from one end of the unit and carefully move the ductwork to one side and carry out maintenance. If on inspection of the unit more access is required, disconnect the unit and remove the other padded fast clamp (or permanent fixings) this will allow careful removal of the fan to carry out maintenance work.

In general, this series of units require very little maintenance. All fan and motor bearings are supplied fully greased and lubricated and are sealed for life. In the unlikely event of component failure, spares are available from stock at VES Andover Ltd.

Spares & Repairs

When enquiring after or ordering spares contact VES Spares Department, quoting the sales order (SO) number and unit type as found on the unit nameplate.

Tel: 02380 46 11 50

WEEE Directive

At the end of their useful life the packaging and product should be disposed of via a suitable recycling centre. Do not dispose of with normal household waste. Do not burn.

PLEASE ENSURE THAT THIS DOCUMENT IS PASSED ON TO THE END USER



roundfan

inline centrifugal fans

Operation & Maintenance Manual

©VES Andover Ltd. 2022
VES is a trading name of VES Andover Ltd.
Registered in England No. 02303719.
Registered Office as above.



Eagle Close, Chandlers Ford Industrial Estate, Chandlers Ford, Eastleigh, Hampshire, SO53 4NF

Tel: +44 (0) 2380 46 11 50

email: info@ves.co.uk

web: www.ves.co.uk